

English Version

## Fixed, vertical road traffic signs - Part 1: Fixed signs

Signaux fixes de signalisation routière verticale - Partie 1 :  
Panneaux fixes

Ortsfeste, vertikale Straßenverkehrszeichen - Teil 1:  
Verkehrszeichen

This European Standard was approved by CEN on 4 February 2007.

CEN members are bound to comply with the CEN/CENELEC Internal Regulations which stipulate the conditions for giving this European Standard the status of a national standard without any alteration. Up-to-date lists and bibliographical references concerning such national standards may be obtained on application to the CEN Management Centre or to any CEN member.

This European Standard exists in three official versions (English, French, German). A version in any other language made by translation under the responsibility of a CEN member into its own language and notified to the CEN Management Centre has the same status as the official versions.

CEN members are the national standards bodies of Austria, Belgium, Bulgaria, Cyprus, Czech Republic, Denmark, Estonia, Finland, France, Germany, Greece, Hungary, Iceland, Ireland, Italy, Latvia, Lithuania, Luxembourg, Malta, Netherlands, Norway, Poland, Portugal, Romania, Slovakia, Slovenia, Spain, Sweden, Switzerland and United Kingdom.



EUROPEAN COMMITTEE FOR STANDARDIZATION  
COMITÉ EUROPÉEN DE NORMALISATION  
EUROPÄISCHES KOMITEE FÜR NORMUNG

**Management Centre: rue de Stassart, 36 B-1050 Brussels**

## Contents

Page

Foreword .....	4
Introduction .....	5
1 Scope.....	6
2 Normative references .....	6
3 Terms, definitions, symbols and abbreviations .....	7
4 Retroreflective sign face material .....	8
4.1 Glass bead material .....	8
4.2 Microprismatic material.....	12
5 Structural performance .....	12
5.1 General.....	12
5.2 Partial safety factors.....	14
5.3 Loads.....	14
5.4 Deflections.....	16
6 Supports .....	20
6.1 Tops.....	20
6.2 Base compartments.....	20
6.3 Performance under vehicle impact .....	20
6.4 Corrosion resistance .....	21
6.5 Base plates .....	21
7 Sign plates, sign faces, transilluminated signs, externally illuminated signs and supports.....	21
7.1 Design .....	21
7.2 Sign faces .....	24
7.3 Transilluminated signs.....	25
7.4 Externally illuminated signs .....	28
8 Sign assemblies .....	30
9 Marking, labelling and product information .....	30
9.1 General.....	30
9.2 Marking and labelling .....	30
9.3 Product information.....	30
9.4 Luminaires .....	31
10 Evaluation of conformity.....	31
11 Dangerous substances.....	31
Annex A (normative) Test points for horizontal and vertical loads .....	32
A.1 Wind load .....	32
A.2 Snow clearance, dynamic load, load combination.....	41

<b>Annex ZA (informative) Clauses of this European Standard addressing the provisions of the EU Construction Products Directive .....</b>	<b>44</b>
<b>ZA.1 Scope and relevant characteristics .....</b>	<b>44</b>
<b>ZA.2 Procedure for attestation of conformity of fixed vertical road traffic signs.....</b>	<b>51</b>
<b>ZA.3 CE marking and labelling.....</b>	<b>52</b>

## Foreword

This document (EN 12899-1:2007) has been prepared by Technical Committee CEN/TC 226 "Road equipment" the secretariat of which is held by AFNOR.

This European Standard shall be given the status of a national standard, either by publication of an identical text or by endorsement, at the latest by May 2008, and conflicting national standards shall be withdrawn at the latest by August 2009.

This document supersedes EN 12899-1:2001.

This European Standard has been prepared under a Mandate given to CEN by the European Commission and the European Free Trade Association and supports essential requirements of EU Directives.

For relationships with EU Directives, see informative Annex ZA, which is an integral part of this standard.

This European Standard consists of the following Parts under the general title:

*Fixed, vertical road traffic signs —*

**Part 1: (This part) Fixed signs**

Part 2: *Transilluminated traffic bollards (TTB)*

Part 3: *Delineator posts and retroreflectors*

Part 4: *Factory production control*

Part 5: *Initial type testing*

It is based on performance requirements and test methods published in CEN, CENELEC, CIE (International Commission on Illumination) and ISO documents together with standards of the CEN member organizations.

According to the CEN/CENELEC Internal Regulations, the national standards organizations of the following countries are bound to implement this European Standard: Austria, Belgium, Bulgaria, Cyprus, Czech Republic, Denmark, Estonia, Finland, France, Germany, Greece, Hungary, Iceland, Ireland, Italy, Latvia, Lithuania, Luxembourg, Malta, Netherlands, Norway, Poland, Portugal, Romania, Slovakia, Slovenia, Spain, Sweden, Switzerland and United Kingdom.

## Introduction

This European Standard is designed for use by road authorities. It can also be used by private developers who wish to use signs on their own land similar to those used on public highways.

This European Standard:

- can be used to implement type approval and certification testing;
- derives from performance requirements and test methods published in CEN, CENELEC, CIE and ISO documents together with standards of the CEN member organizations;
- does not require the replacement of existing signs;
- covers performance requirements and test methods;
- defines performance limits and a range of performance classes. Colorimetric and retroreflective properties, as well as the luminance and illuminance, are specified;

The retroreflective requirements and tests in respect of materials based on glass bead technology are specified in this standard. The performance of retroreflective materials using microprismatic technology is specified in the relevant ETA which enables CE marking of such material.

Wind actions can be specified by the use of either values in this standard or by the methods specified in EN 1991-1-4.

Structural requirements for signs complete with sign supports include performance under static and dynamic loading. Provision is made for safety in use, including vehicle impact.

## **1 Scope**

This Part 1 of EN 12899 specifies requirements for complete sign assemblies (including supports), signs (sign plates with sign faces), sign plates (without sign faces) and for other major components (retroreflective sheeting, supports and luminaires).

The main intended use of fixed signs is for the instruction and guidance of road users on public and private land.

Matters not covered by this standard:

- a) sign gantry and cantilever structures; 
- b) signs with discontinuous messages, e.g. using light emitting diodes (LED), or fibre optics;
- c) variable message signs;
- d) signs used for temporary purposes;
- e) foundations;
- f) tests for extremely low temperatures.

## **2 Normative references**

The following referenced documents are indispensable for the application of this document. For dated references, only the edition cited applies. For undated references, the latest edition of the referenced document (including any amendments) applies.

EN 1011, *Welding - Recommendations for welding of metallic materials*

EN 1991-1-4, *Eurocode 1: Actions on structures - Part 1-4: General actions - Wind actions*

EN 1993-1-1, *Eurocode 3: Design of steel structures — Part 1-1: General rules and rules for buildings*

EN 1995-1-1, *Eurocode 5: Design of timber structures - Part 1-1: General - Common rules and rules for buildings*

EN 1999-1-1, *Eurocode 9: Design of aluminium structures — Part 1-1: General rules – General rules and rules for buildings*

EN 10240, *Internal and/or external protective coatings for steel tubes - Specification for hot dip galvanized coatings applied in automatic plants*

EN 12665:2002, *Light and lighting – Basic terms and criteria for specifying lighting requirements*

EN 12767, *Passive safety of support structures for road equipment - Requirements and test methods*

EN 12899-4, *Fixed vertical road traffic signs – Part 4: Factory production control*

EN 12899-5, *Fixed vertical road traffic signs – Part 5: Initial type testing*

EN 13032-1, *Light and lighting - Measurement and presentation of photometric data of lamps and luminaires – Part 1: Measurement and file format*

EN 13201-3, *Road lighting – Part 3: Calculation of performance*

EN 60529, *Degrees of protection provided by enclosures (IP code) (IEC 60529:1989)*

EN ISO 139, *Textiles - Standard atmospheres for conditioning and testing (ISO 139:2005)*

EN ISO 877:1996, *Plastics - Methods of exposure to direct weathering, to weathering using glass-filtered daylight, and to intensified weathering by daylight using Fresnel mirrors (ISO 877:1994)*

EN ISO 1461 *Hot dip galvanized coatings on fabricated iron and steel articles - Specifications and test methods (ISO 1461:1999)*

EN ISO 4892-2, *Plastics - Methods of exposure to laboratory light sources - Part 2: Xenon-arc lamps (ISO 4892-2:2006)*

EN ISO 6272, *Paints and varnishes - Rapid-deformation (impact resistance) tests*

EN ISO 9001, - *Quality management systems - Requirements (ISO 9001:2000)*

ISO 4:1997, *Information and documentation — Rules for the abbreviation of title words and titles of publications*

CIE 15, *Colorimetry*

CIE 54.2, *Retroreflection – Definition and measurement*

CIE 74:1988, *Road signs*

### **3 Terms, definitions, symbols and abbreviations**

For the purposes of this document, the symbols and abbreviations given in ISO 4:1997 apply. The photometric terms and definitions given in EN 12665:2002 and the sign descriptions given in CIE 74:1988 also apply, together with the following.

#### **3.1**

##### **sign assembly**

complete assembly including the sign plate, sign face material and supports

#### **3.2**

##### **sign**

sign plate with the sign face material applied

#### **3.3**

##### **sign plate**

fabrication comprising the substrate, reinforcing members and fixings

#### **3.4**

##### **protective edge**

fabrication intended to reinforce the edge of the sign and to reduce the severity of personal injury in the event of bodily impact with the sign edge

#### **3.5**

##### **substrate**

material used to support the sign face material

#### **3.6**

##### **sign face material**

material or materials applied to the substrate to produce the finished surface of the fixed sign

**3.7**

**standard shape sign faces**

circles, triangles, squares, diamonds and octagons containing legends in accordance with the provisions of the Vienna Convention

**3.8**

**mounting height (*H*)**

distance from ground level to the lower edge of the sign plate

**3.9**

**support**

component which supports the sign plate

**3.10**

**temporary deflection**

displacement of the structural component under load which returns to zero when the load is removed

**3.11**

**permanent deflection**

deflection which remains after the load is removed

**3.12**

**production identification code**

code defined by the manufacturer in order to achieve traceability

## **4 Retroreflective sign face material**

### **4.1 Glass bead material**

#### **4.1.1 Visual performance**

##### **4.1.1.1 Test conditions**

Tests shall be carried out at a temperature of  $(23 \pm 3)$  °C and a relative humidity of  $(50 \pm 5)$  % unless otherwise specified.

##### **4.1.1.2 Test samples**

Tests shall be conducted on finished products, or on prepared samples representative of finished products and suitable for the test equipment.

Test samples and test panels shall be conditioned in accordance with EN ISO 139 and shall be identified on the back.

##### **4.1.1.3 Daylight chromaticity and luminance factor**

When tested in accordance with the relevant procedure specified in CIE 15, using CIE standard daylight illuminant D65 and the standard CIE 45/0 viewing conditions, the chromaticity and the luminance factor  $\beta$  shall conform to Table 1 or Table 2 as appropriate.



Table 1 — Daylight chromaticity and luminance factors. Class CR1

Colour	1		2		3		4		Luminance factor $\beta$	
	x	y	x	y	x	y	x	y	Table 3	Table 4
White	0,355	0,355	0,305	0,305	0,285	0,325	0,335	0,375	$\geq 0,35$	$\geq 0,27$
Yellow see Table 3	0,522	0,477	0,470	0,440	0,427	0,483	0,465	0,534	$\geq 0,27$	
Yellow see Table 4	0,545	0,454	0,487	0,423	0,427	0,483	0,465	0,534		$\geq 0,16$
Orange	0,610	0,390	0,535	0,375	0,506	0,404	0,570	0,429	$\geq 0,17$	$\geq 0,14$
Red	0,735	0,265	0,674	0,236	0,569	0,341	0,655	0,345	$\geq 0,05$	$\geq 0,03$
Blue	0,078	0,171	0,150	0,220	0,210	0,160	0,137	0,038	$\geq 0,01$	$\geq 0,01$
Green	0,007	0,703	0,248	0,409	0,177	0,362	0,026	0,399	$\geq 0,04$	$\geq 0,03$
Dark green	0,313	0,682	0,313	0,453	0,248	0,409	0,127	0,557	$0,01 \leq \beta \leq 0,07$	
Brown	0,455	0,397	0,523	0,429	0,479	0,373	0,558	0,394	$0,03 \leq \beta \leq 0,09$	
Grey	0,350	0,360	0,300	0,310	0,285	0,325	0,335	0,375	$0,12 \leq \beta \leq 0,18$	

Table 2 — Daylight chromaticity and luminance factors. Class CR2

Colour	1		2		3		4		Luminance factor $\beta$	
	x	y	x	y	x	y	x	y	Table 3	Table 4
White	0,305	0,315	0,335	0,345	0,325	0,355	0,295	0,325	$\geq 0,35$	$\geq 0,27$
Yellow see Table 3	0,494	0,505	0,470	0,480	0,493	0,457	0,522	0,477	$\geq 0,27$	
Yellow see Table 4	0,494	0,505	0,470	0,480	0,513	0,437	0,545	0,454		$\geq 0,16$
Red	0,735	0,265	0,700	0,250	0,610	0,340	0,660	0,340	$\geq 0,05$	$\geq 0,03$
Blue see Table 3	0,130	0,086	0,160	0,086	0,160	0,120	0,130	0,120	$\geq 0,01$	
Blue see Table 4	0,130	0,090	0,160	0,090	0,160	0,140	0,130	0,140		$\geq 0,01$
Green see Table 3	0,110	0,415	0,150	0,415	0,150	0,455	0,110	0,455	$\geq 0,04$	
Green see Table 4	0,110	0,415	0,170	0,415	0,170	0,500	0,110	0,500		$\geq 0,03$
Dark green	0,190	0,580	0,190	0,520	0,230	0,580	0,230	0,520	$0,01 \leq \beta \leq 0,07$	
Brown	0,455	0,397	0,523	0,429	0,479	0,373	0,558	0,394	$0,03 \leq \beta \leq 0,09$	
Grey	0,305	0,315	0,335	0,345	0,325	0,355	0,295	0,325	$0,12 \leq \beta \leq 0,18$	

NOTE The limits specified in Table 1, with the exception of dark green, brown and grey, are recommended in CIE 39.2 as surface colours for visual signalling. When colours deteriorate beyond these chromaticity limits the signs can be unsuitable for the intended purpose. The chromaticity limits specified in Table 2 can ensure a more uniform appearance and consistency in the colour of new signs which are installed at different times than the limits specified in Table 1. Colours conforming to the limits of Table 2 can also be expected to take longer to deteriorate beyond the limits of Table 1.

4.1.1.4 Coefficient of retroreflection  $R_A$

When measured in accordance with the procedure specified in CIE 54.2, using CIE standard illuminant A, the minimum initial coefficient of retroreflection  $R_A$  ( $\text{cd} \cdot \text{lx}^{-1} \cdot \text{m}^{-2}$ ) of retroreflective material, using glass bead technology, shall be not less than the values in Table 3 or Table 4, as appropriate.

The coefficient of retroreflection ( $R_A$ ) of all printed colours, except white, shall be not less than 70 % of the values in Table 3 or Table 4 for Class RA1 and Class RA2 signs respectively.

Table 3 — Coefficient of retroreflection  $R_A$  Class RA1

unit:  $\text{cd} \cdot \text{lx}^{-1} \cdot \text{m}^{-2}$

Geometry of measurements		Colour							
$\alpha$	$\beta_1$ ( $\beta_2 = 0$ )	White	Yellow	Red	Green	Blue	Brown	Orange	Grey
12'	+5°	70	50	14,5	9	4	1	25	42
	+30°	30	22	6	3,5	1,7	0,3	10	18
	+40°	10	7	2	1,5	0,5	#	2,2	6
20'	+5°	50	35	10	7	2	0,6	20	30
	+30°	24	16	4	3	1	0,2	8	14,4
	+40°	9	6	1,8	1,2	#	#	2,2	5,4
2°	+5°	5	3	1	0,5	#	#	1,2	3
	+30°	2,5	1,5	0,5	0,3	#	#	0,5	1,5
	+40°	1,5	1,0	0,5	0,2	#	#	#	0,9
# Indicates "Value greater than zero but not significant or applicable".									

Table 4 — Coefficient of retroreflection  $R_A$  Class RA2unit:  $\text{cd.lx}^{-1}.\text{m}^{-2}$ 

Geometry of measurements		Colour								
$\alpha$	$\beta_1$ $\beta_2 = 0$	White	Yellow	Red	Green	Dark green	Blue	Brown	Orange	Grey
12'	+5°	250	170	45	45	20	20	12	100	125
	+30°	150	100	25	25	15	11	8,5	60	75
	+40°	110	70	15	12	6	8	5,0	29	55
20'	+5°	180	120	25	21	14	14	8	65	90
	+30°	100	70	14	12	11	8	5	40	50
	+40°	95	60	13	11	5	7	3	20	47
2°	+5°	5	3	1	0,5	0,5	0,2	0,2	1,5	2,5
	+30°	2,5	1,5	0,4	0,3	0,3	#	#	1	1,2
	+40°	1,5	1,0	0,3	0,2	0,2	#	#	#	0,7
# Indicates "Value greater than zero but not significant or applicable".										

#### 4.1.1.5 Durability

##### 4.1.1.5.1 Resistance to weathering

After weathering in accordance with 4.1.1.5.2 or 4.1.1.5.3, the following requirements shall apply.

The chromaticity and luminance factor of materials using glass beads technology shall conform to the requirements of 4.1.1.3 as appropriate.

When tested at an observation angle ( $\alpha$ ) of 20' and entrance angles ( $\beta_1 = 5^\circ$  and  $30^\circ$ , with  $\beta_2 = 0^\circ$ ) the coefficient of retroreflection shall be not less than 80 % of the values required in 4.1.1.4 as appropriate.

##### 4.1.1.5.2 Accelerated natural weathering

Samples of material shall be exposed, inclined at an angle of  $45^\circ$  to the horizontal and facing the equator, in accordance with EN ISO 877:1996, Method A for three years.

##### 4.1.1.5.3 Accelerated artificial weathering

The manufacturer may use accelerated artificial weathering to predict durability but testing shall be commenced by accelerated natural weathering not later than the start of the accelerated artificial weathering. The result of accelerated natural weathering shall take precedence over the result of accelerated artificial weathering.

The apparatus shall be either an air-cooled or water-cooled Xenon arc weathering device capable of exposing samples in accordance with EN ISO 4892-2.

Preparation of test specimens shall be in accordance with the general guideline given in EN ISO 4892-2.

The samples shall be exposed in accordance with EN ISO 4892-2 using the parameters given in Table 5, for a period of 2000 h.

Table 5 — Artificial weathering test parameters

Exposure parameters	Air-cooled lamp	Water-cooled lamp
Light/dark/water spray cycle	Continuous light with water spray on specimens for 18 min every 2 h	Continuous light with water spray on specimens for 18 min every 2 h
Black standard temperature during light only periods	(65 ± 3) °C using a black standard thermometer	(65 ± 3) °C using a black standard thermometer
Relative humidity	(50 ± 5) %	(50 ± 5) %
Irradiance (W/m <sup>2</sup> ) controlled at — over 300 nm to 400 nm range — over 300 nm to 800 nm range	60 550	60 630
NOTE 1 Water used for specimen spray should contain no more than 1 ppm silica. Higher levels of silica can produce spotting on samples and variability in results. Water of the required purity can be obtained by distillation or by a combination of deionization and reverse osmosis.		
NOTE 2 Whilst irradiance levels should be set at the above levels, variations in filter ages and transmissivity, and in calibration variations, will generally mean that irradiance error will be in the order of ± 10 %.		

#### 4.1.2 Impact resistance

When tested in accordance with EN ISO 6272, using a mass of 450 g with a contact radius of 50 mm dropped from a height of 220 mm, there shall be no cracking or, for sign face sheeting material, delamination from any substrate, outside a circle of 6 mm radius with the point of impact as the centre.

The test sign shall be supported as it would be when installed, or the test sample shall be supported over an open area of 100 mm x 100 mm.

#### 4.2 Microprismatic material

The performance of retroreflective materials using microprismatic technology can be found in the relevant European Technical Approval (ETA). The manufacturer shall obtain the performance specifications from the purchaser.

NOTE The testing procedure for retroreflective materials using microprismatic technology can be found in the relevant European Technical Approval (ETA).

### 5 Structural performance

#### 5.1 General

Steel constructions and steel mounting elements shall conform to EN 1993-1-1.

Aluminium constructions shall conform to EN 1999-1-1.

Timber constructions shall conform to EN 1995-1-1.

Welded fabrications shall conform to EN 1011, as appropriate.

Other materials are acceptable but if they are used they shall enable conformity to this standard.

All components and assemblies shall withstand dead and live loading, multiplied by the appropriate partial safety factor from 5.2.

Verification of performance may either be by calculation or by testing.

When verification of performance is to be by calculation, the structural performance of signs and their supports and fixings shall be calculated in accordance with 5.4.3.

When verification of performance is to be done by testing, tests shall be made in accordance with 5.4.4. The deflections to be calculated shall be those between the sign and support, or between the supports and the foundations.

The deflections of sign plates are evaluated relative to the supports. The deflections of supports are evaluated separately, except in the case of large supporting structures such as sign gantries, the deflections of which are not considered as they are outside the scope of this document.

When supports are to be supplied for stock, or otherwise where the conditions of use are not known at the time of manufacture of the support, the support manufacturer shall supply information on the structural performance of the support to enable the structural performance of the complete assembly to be calculated. The structural information to be provided shall be:

either

(a) for supports of constant cross-section:

- maximum bending moment  $M_u$  (kNm);
- stiffness for bending  $EI$  (kNm<sup>2</sup>);
- maximum moment for torsion  $T_u$  (kNm);
- stiffness for torsion  $GJ_t$  (kN·m<sup>2</sup>);

NOTE 1  $EI$  = modulus of elasticity x moment of inertia.

NOTE 2  $GJ_t$  = shear modulus x torsion constant.

For a non-constant cross-section, equivalent values shall be given related to the actual length of the support.

or (b) the type and grade of material and all the dimensions;

or (c) verification of conformity to a purchaser's prescriptive specification for materials and dimensions.

Information to be provided in case (a) may be obtained by calculation in accordance with 5.4.3 or by physical testing in accordance with 5.4.4. The criterion for the maximum bending moment  $M_u$  and the maximum moment for torsion  $T_u$  shall be as 5.4.4.4.

The declared maximum bending moment shall be given at the designed ground level. If the weakest point is other than at ground level the equivalent value at ground level shall be given.

Any other relevant information shall be given as part of the manufacturer's supporting data, e.g. details and strength of fixings integral to the supports.

NOTE 3 Case (b) can be adequate for supports of simple construction, for instance comprising a standard metal tube of any standard cross-sectional shape.

## 5.2 Partial safety factors

The safety factors for loads shall be in accordance with Table 6.

**Table 6 — Partial safety factors  $\gamma_f$**

PAF class	Wind, dynamic snow and point loads	Dead load
PAF1	1,35	1,2
PAF2	1,50	1,35

The safety factors for materials shall be in accordance with Table 7.

**Table 7 — Partial material factors  $\gamma_m$**

Material	$\gamma_m$
Steel	1,05
Aluminium	1,15
Timber	1,35
Fibre reinforced polymer	1,50
Plastics	1,80

To obtain the overall safety factor, multiply the figures from Table 6 and Table 7.

## 5.3 Loads

### 5.3.1 Wind actions

#### 5.3.1.1 General

The wind pressure may be either calculated by the method in 5.3.1.2 or taken from Table 8.

In either case the wind load shall be multiplied by the shape factor. The shape factor for flat signs is 1.20.

In both cases the wind pressure shall be applied as a uniformly distributed load over the area of the sign plate and act at the centre of pressure of the sign plate in order to calculate the bending moments in the supports and sign plate.

The eccentricity value shall be declared in the requirements and in the evaluation report of the product.

NOTE This is often taken as zero however purchasers can require different values as they affect the bending moment applied to the post.

#### 5.3.1.2 Calculation of wind pressure

Wind actions shall be calculated in accordance with EN 1991-1-4. The calculations shall identify whether they are based on a 25 year or a 50 year reference wind speed.

The reference wind speed shall be appropriate to the sign location taken from the location data.

### 5.3.1.3 Classes of wind pressure

The wind pressure for calculating the structural integrity of the sign plate, fixings and supports shall be in accordance with Table 8.

**Table 8 — Wind pressure**

Class	Wind pressure kN.m <sup>-2</sup>
WL0	No performance determined
WL1	0,40
WL2	0,60
WL3	0,80
WL4	0,90
WL5	1,00
WL6	1,20
WL7	1,40
WL8	1,50
WL9	1,60

NOTE 1 Wind speeds in mountainous, coastal and estuarial regions can be as much as 40 % above speeds in other areas. Purchasers should consider specifying a higher class of wind load or reference wind speed for these locations.

NOTE 2 The wind pressures in Table 8 do not include safety factors and shape factors.

### 5.3.2 Dynamic pressure from snow clearance

The dynamic pressure from snow clearance, from Table 9, shall be applied to the areas indicated in Annex A. This load is not simultaneous with wind load and point load.

**Table 9 — Dynamic snow pressure**

Class	Dynamic snow pressure kN.m <sup>-2</sup>
DSL0	No performance determined
DSL1	1,5
DSL2	2,5
DSL3	3,0
DSL4	4,0

### 5.3.3 Point loads

The point load, from Table 10, shall be placed as indicated in Annex A. This load is not applied simultaneously with the wind load and snow load. The acceptance criterion shall be as given in 5.4.2.

**Table 10 — Point loads**

<b>Class</b>	<b>Point load kN</b>
PL0	No performance determined
PL1	0,15
PL2	0,30
PL3	0,50
PL4	0,75
PL5	1,00

#### 5.3.4 Dead loads

Dead loads shall be the combined weight of the individual components of the finished sign such as substrate, sign housing, protective edge, stiffeners, luminaires, supports, fixings etc.

The acceptance criterion shall be as given in 5.4.2.

#### 5.4 Deflections

##### 5.4.1 Temporary deflections

The wind load for calculating the temporary deflection shall be based on the wind loads multiplied by 0,56, and no partial action and material factors are applied.

NOTE 1 The factor of 0,56 is derived from the 50 year wind speed reduction to one year wind speeds.

Temporary deflections from wind actions only shall be calculated in accordance with 5.4.3 or tested in accordance with 5.4.4.

The temporary deflection of the sign plate, specified from Table 11, shall be determined at the point where the deflection is greatest (see Figures A.1 to A.7).

The maximum temporary deflection of the supports relative to the foundations shall conform to the deflection class(es) chosen from Tables 11 and 12.

**Table 11 — Maximum temporary deflection – Bending**

<b>Class</b>	<b>Bending mm·m<sup>-1</sup></b>
TDB0	No performance determined
TDB1	2
TDB2	5
TDB3	10
TDB4	25
TDB5	50
TDB6	100



**Table 12 — Maximum temporary deflection – Torsion**

<b>Class</b>	<b>Torsion degree·m<sup>-1</sup></b>
TDT0	No performance determined
TDT1	0,02
TDT2	0,06
TDT3	0,11
TDT4	0,29
TDT5	0,57
TDT6	1,15

NOTE 2 Table 12 only applies to a single sign support subjected to torsion from an asymmetrical load, position or shape of the sign.

#### **5.4.2 Permanent deflections**

Permanent deflections shall be assessed using the following loads: 25 year or 50 year wind load, dynamic snow load, point load and dead load. The partial action and material factors are applied.

When the structural performance is evaluated by means of a physical test, the maximum permanent deflection shall not exceed 20 % of the temporary deflection using the same load.

NOTE This takes into account the slack in the fixings and other non-elastic phenomena.

When the structural performance is evaluated by calculation, the material stresses shall not exceed the elastic limit.

#### **5.4.3 Calculations for the verification of physical performance**

The construction shall be designed in such a way that the deformation shall stay in the elastic region when applying the specified (25 year or 50 year) wind load, point load or dynamic load from snow clearance.

Calculations shall be in accordance with, and fulfil the requirements of, EN 1993-1-1, EN 1995-1-1 or EN 1999-1-1 as appropriate.

The relevant safety factors in 5.2 and shape factors for the individual member shall be applied when calculating the loading.

When calculating temporary deflections, only shape factors for the individual member shall be applied.

#### **5.4.4 Test method for the verification of physical performance**

##### **5.4.4.1 Apparatus and materials**

- A rigid test structure, on which to clamp or mount a support, sign plate or complete assembly in the horizontal plane. The deflection of the structure shall not exceed Tables 11 and/or 12 for the declared class.
- Means of fixing the test item, so that it cannot rotate or deflect during the test at the point or points at which it is fixed. The test item shall be mounted with sufficient clear space beneath to permit foreseeable deflections.
- Means of applying a load, equivalent to the specified horizontal and vertical loads.
- Means of measuring deflections.

##### **5.4.4.2 Procedure for the sign plate**

The following procedure shall be used:

- Fix the sign plate to the test structure using the same fixings as are to be used in service, at as many points as in its intended use. Take into account the number and location of supports and fixings that would be applied in the intended use of the sign. To simulate symmetric mounting on a single vertical support, ensure the fixings are in the vertical centre line of the sign.
- Apply the specified load;
- Release the load;
- Zero the deflection measuring equipment;
- Apply the charge;
- Maintain the load for 5 min;
- Measure and record the deflection at the following location:
  - the extremities of the horizontal side for triangles;
  - the extremities of the horizontal axis for other sign shapes;
  - the mid-point between each pair of fixings on the horizontal axis (where more than one support is intended).
- Release the load;
- Immediately measure and record the permanent deflection at the same location;
- When relevant, re-mount the same test sign plate so that it can be loaded on the reverse face and repeat the above procedure.

NOTE 1 Loading on the reverse face will apply only in the case of wind loading and horizontal point loads.

NOTE 2 The expressions "vertical axis", "horizontal side" and "horizontal axis" used, apply as if the sign was in its normal upright position.

NOTE 3 Uniform distribution of the test load can be ensured by dividing the surface under test into squares and loading the area of each square to the required amount. Lead shot is recommended as it is more stable when being placed in position.

NOTE 4 The loads specified for wind loads are different for temporary and permanent deflections (see 5.4.1 and 5.4.2).

#### 5.4.4.3 Procedure for the support where the loads are known

To determine the deflection of the support follow the procedure below.

- Apply the specified load (wind, dynamic snow or point) measuring the deflection at the top of the support.
- Release the load.
- Zero the measuring device.
- Apply the charge.
- Maintain the load for 5 min.
- Measure the deflection at the top of the support while the load is applied.
- Release the load.
- Measure the permanent deflection.

To determine the torsional deflection of the support:

- Mount or clamp the support securely so that it cannot rotate or deflect at the base and restrain its top so that it is free to rotate, but otherwise remains fixed. Repeat the procedure, measuring the rotation at the top of the support.

NOTE The loads specified for wind loads are different for temporary and permanent deflections (see 5.4.1 and 5.4.2).

#### 5.4.4.4 Procedure for supports where the loads are unknown

To determine the maximum bending moment of the support, mount or clamp the support securely so that it cannot rotate or deflect at the base and follow the procedure below.

- Apply loads to the top of the support in small increments, while measuring the deflection at the top of the support.
- Increase the load until the first numerical deflection in the relevant table is exceeded (see Table 11 for deflection due to bending, and Table 12 for rotation due to torsion).
- Release the load.
- Zero the measuring device.
- Apply loads in small increments, until the first numerical deflection in the table is reached.
- Maintain the load for 5 min.
- Measure the deflection and record the deflection and the load.
- Release the load.

## EN 12899-1:2007 (E)

- Measure and record the permanent deflection.
- Repeat steps 5 to 9 above, increasing the loads for successive deflections in the table.
- Stop the procedure when the permanent deflection becomes larger than 20 % of the temporary deflection.

Maximum bending moment  $M_u$  (kN·m) is calculated from the highest load which does not cause a permanent deflection greater than 20 % of the temporary deflection multiplied by the distance of the load from designed ground surface.

$EI$  is calculated from the load, the location of the load and the deflection observed in the test.

For torsion of the support, the procedure shall be as follows.

Mount or clamp the support securely so that it cannot rotate or deflect at the base and restrain its top so that it is free to rotate, but otherwise remains fixed. Repeat the procedure, measuring the rotation at the top of the support in degrees.

The maximum moment for torsion  $T_u$  (kN·m) is calculated from the highest load which does not cause a permanent deflection greater than 20 % of the temporary deflection multiplied by the distance of the centre of the support.

$GI_t$  is calculated from the load, the location of the load and the torsional deflection observed in the test.

### 5.4.4.5 Procedure for fixings

- Mount the complete sign assembly vertically and apply the vertical point load.
- Determine whether the sign plate slides on the support.
- Clamp the support and apply the horizontal point load.
- Determine whether the sign plate rotates on the support.

## 6 Supports

### 6.1 Tops

Hollow section supports shall if required be sealed at the top to prevent ingress of water.

Sealing may take the form of a separate cap to be fitted during construction or installation of the assembly.

### 6.2 Base compartments

Where electrical apparatus is to be housed in a support, the support shall be fitted with a base compartment with an IP rating of IP3x or as specified by the purchaser.

### 6.3 Performance under vehicle impact

The performance of the support under vehicle impact shall be declared to conform to a performance class from EN 12767. If the support does not conform to a performance class it shall be declared to be class 0 under EN 12767.

## 6.4 Corrosion resistance

The material of the support, the system of protection and the class of corrosion resistance in accordance with 7.1.7 shall be declared.

## 6.5 Base plates

Circular hollow section supports shall if required be fitted with a base plate or other device to prevent rotation in the ground or foundation.

Base plates or other devices may take the form of a separate component to be fitted during construction or installation of the sign assembly.

## 7 Sign plates, sign faces, transilluminated signs, externally illuminated signs and supports

### 7.1 Design

#### 7.1.1 General

For products used to manufacture complete signs, the product shall conform to the appropriate parts of this or other relevant European or International Standards.

#### 7.1.2 Colour of the back

The Manufacturer shall ensure that the colour of the back of the sign plate is in accordance of the purchaser's requirements.

#### 7.1.3 Dimensions and tolerances

The dimensions and the signs faces shall be in accordance to the purchaser's requirements.

#### 7.1.4 Corner radii

Unless otherwise specified in the purchaser's requirements, the corner radii shall be not less than 10 mm.

#### 7.1.5 Piercing

When sign substrates are stiffened with additional reinforcing members, these shall be fixed to the sign substrate in accordance with Table 13.

**Table 13 — Piercing of sign face**

Class	Requirements
P1	The sign face shall be pierced only at intervals of not less than 150 mm in any direction, except when required for the purpose of securing the sign substrate to the supporting structure
P2	The sign face shall not be pierced, except when required for the purpose of securing the sign substrate to the supporting structure
P3	The sign face shall not be pierced for any reason

### 7.1.6 Sign plate edges

Sign edges shall conform to Table 14.

**Table 14 — Edges of sign plates**

Class	Requirements
E1	Non-protective, the substrate being a flat sheet of material
E2	Protective, with the edge stamped, formed, pressed, or covered by an edging profile
E3	Protective, protection being provided by the mounting structure

### 7.1.7 Corrosion resistance

The classes of surface protection against corrosion shall be in accordance with Table 15.

**Table 15 — Surface protection**

Class	Requirements
SP0	Surface protection not provided
SP1	Protective coatings provided
SP2	Inherent surface protection provided

Hot dip galvanizing shall conform to EN ISO 1461 or EN 10240.

Any part of an aluminium support which is to be placed underground shall have a protective coating applied in accordance with the instructions and recommendations of the manufacturer of the surface coating.

The manufacturer shall apply surface coating in accordance with the instructions and recommendations of the manufacturer of the surface coating.

Timber components shall be treated for preservation in accordance with the instructions and recommendations of the manufacturer of the preservation material.

### 7.1.8 Protection from foreign objects and water

The minimum levels of protection of transilluminated sign housings, luminaires and luminaire housings against penetration by dust and water, specified in EN 60529, shall be level 2 for solid particles and level 3 for water.

NOTE This does not exclude the possibility of a purchaser specifying a higher level of protection.

### 7.1.9 Light sources and circuits

Lit signs may have either a single light source or multiple light sources.

Multiple light source circuits shall be arranged so that in the event of one circuit failure, the sign will remain evenly illuminated.

### 7.1.10 Colour rendering of light sources

Light sources installed in transilluminated signs, or in luminaires for external illumination of road signs, shall be of types with a general colour rendering index Ra, as defined in EN 12665, of a minimum value of 60.

NOTE Improved performance can be obtained with light sources with a colour rendering index of 80.

### 7.1.11 Transilluminated sign housings

Sign housings for transilluminated signs shall be designed to ensure reliable transfer of all static and dynamic forces to the fixing and mounting structures. The walls of the housing shall be designed to satisfy the static requirements. Corners shall be rounded. The design shall ensure that rainwater does not run off the housing and down the sign face.

### 7.1.12 External lighting units

Luminaires for the external illumination of signs shall be of the enclosed type. The structural design shall include the whole structure consisting of housing, support and fixings. The luminaire shall incorporate light source, control equipment, reflector and cover or lens.

Luminaires for the external illumination of signs shall be mounted so that they do not hide any part of the sign face from the view of drivers and do not lead to surface reflections in the sign face material as seen in normal viewing directions.

NOTE Surface reflections are normally avoided when directions of illumination form angles to the normal of the sign face greater than 30°. This can be obtained by mounting the luminaires below the road sign, above it or at the sides. Each of these mounting arrangements have advantages and disadvantages, e.g. reduced free height below the luminaires and possibly light shining in the eyes of drivers travelling in the opposite direction. This latter problem can be reduced by an extension of the sign plate.

### 7.1.13 Electrical

Mounting devices shall have cable entries to accommodate cable connection equipment.

NOTE The Low Voltage and EMC Directives apply to electrical components.

Means shall be provided to correct the power factor in accordance with national electricity supply requirements.

The nominal life of light sources shall be declared by the manufacturer.

### 7.1.14 Fixings

Sign fixings shall fit sign supports so that they prevent sliding on or rotation around the support and enable conformance to 5.1 when the specified vertical or horizontal load from Table 9 is applied. Sign fixings shall also conform to 7.1.7.

## 7.2 Sign faces

### 7.2.1 Retroreflective sign faces

These shall conform to Clause 4.

### 7.2.2 Non-retroreflective sign faces

#### 7.2.2.1 Visual performance

##### 7.2.2.1.1 Test conditions

Test conditions shall conform to 4.1.1.1.

##### 7.2.2.1.2 Test samples

Test samples shall conform to 4.1.1.2.

##### 7.2.2.1.3 Daylight chromaticity and luminance factor of non-retroreflective signs

When tested in accordance with the relevant procedure specified in CIE 15, using CIE standard daylight illuminant D65 and the standard CIE 45/0 viewing conditions, the chromaticity and the luminance factor  $\beta$  shall conform to Table 16 or Table 17 as appropriate.

**Table 16 — Daylight chromaticity and luminance factors NR 1: Non-retroreflective signs**

Colour	1		2		3		4		Luminance factor $\beta$
	x	y	x	y	x	y	x	y	
White	0,350	0,360	0,300	0,310	0,290	0,320	0,340	0,370	$\geq 0,75$
Yellow	0,522	0,477	0,470	0,440	0,427	0,483	0,465	0,534	$\geq 0,45$
Orange	0,610	0,390	0,535	0,375	0,506	0,404	0,570	0,429	$\geq 0,20$
Red	0,735	0,265	0,674	0,236	0,569	0,341	0,655	0,345	$\geq 0,07$
Blue	0,078	0,171	0,196	0,250	0,225	0,184	0,137	0,038	$\geq 0,05$
Green	0,313	0,682	0,313	0,453	0,177	0,362	0,026	0,399	$\geq 0,10$
Brown	0,510	0,370	0,427	0,353	0,407	0,373	0,475	0,405	$0,04 \leq \beta \leq 0,15$
Grey	0,350	0,360	0,300	0,310	0,290	0,320	0,340	0,370	$0,16 \leq \beta \leq 0,24$
Black	0,385	0,355	0,300	0,270	0,260	0,310	0,345	0,395	$\leq 0,03$

**Table 17 — Daylight chromaticity and luminance factors NR2: Non-retroreflective signs**

Colour	1		2		3		4		Luminance factor $\beta$
	x	y	x	y	x	y	x	y	
White	0,305	0,315	0,335	0,345	0,325	0,355	0,295	0,325	$\geq 0,75$
Yellow	0,494	0,505	0,470	0,480	0,493	0,457	0,522	0,477	$\geq 0,45$
Red	0,735	0,265	0,700	0,250	0,610	0,340	0,660	0,340	$\geq 0,07$
Green	0,230	0,440	0,260	0,440	0,260	0,470	0,230	0,470	$\geq 0,10$
Blue	0,140	0,140	0,160	0,140	0,160	0,160	0,140	0,160	$\geq 0,05$
Brown	0,467	0,386	0,447	0,386	0,447	0,366	0,467	0,366	$0,04 \leq \beta \leq 0,15$
Grey	0,305	0,315	0,335	0,345	0,325	0,355	0,295	0,325	$0,16 \leq \beta \leq 0,24$



NOTE The limits specified in Table 16, with the exception of brown and grey, are recommended in CIE 39.2 as surface colours for visual signalling. When colours deteriorate beyond these chromaticity limits, in some cases the signs will not be suitable for the intended purpose. The chromaticity limits specified in Table 17 ensure a more uniform appearance and consistency in the colour of new signs which are installed at different times than the limits specified in Table 16. Colours conforming to the limits of Table 17 can also be expected to take longer to deteriorate beyond the limits of Table 16.

#### **7.2.2.1.4 Durability of visual performance**

Test samples of non-retroreflective material shall be exposed, inclined at an angle of 45° to the horizontal and facing the equator, in accordance with EN ISO 877:1996, Method A for two years.

When tested after exposure the chromaticity and luminance factor shall conform to the requirements of 7.2.2.1.3 as appropriate.

#### **7.2.2.2 Impact resistance**

Impact resistance shall be verified using the procedure in 4.1.2.

### **7.3 Transilluminated signs**

#### **7.3.1 Visual performance**

##### **7.3.1.1 Test conditions**

Test conditions shall conform to 4.1.1.1.

##### **7.3.1.2 Test samples**

Tests shall be conducted on prepared samples representative of finished products and suitable for the test equipment. Any substrate used for the samples shall be non reflective.

Test samples and test panels shall be conditioned in accordance with EN ISO 139 and shall be identified on the back.

##### **7.3.1.3 Daylight chromaticity and luminance factor**

When tested in accordance with the relevant procedure specified in CIE 15, using CIE standard daylight illuminant D65 and the standard CIE 45/0 viewing conditions, the chromaticity and the luminance factor  $\beta$  shall be in accordance with Table 18.

Table 18 — Daylight chromaticity and luminance factors

Colour	1		2		3		4		Luminance factor $\beta$ Class B1		Luminance factor $\beta$ Class B2	
	x	y	X	y	x	y	x	y	min.	max.	min.	max.
Red	0,690	0,310	0,595	0,315	0,569	0,341	0,655	0,345	0,03		0,07	
Orange	0,610	0,390	0,535	0,375	0,506	0,404	0,570	0,429	0,20		0,20	
Yellow	0,522	0,477	0,470	0,440	0,427	0,483	0,465	0,534	0,24		0,45	
Green	0,313	0,682	0,313	0,453	0,209	0,383	0,013	0,486	0,03		0,10	
Dark Green	0,313	0,682	0,313	0,453	0,177	0,362	0,026	0,399	0,03		0,10	
Blue	0,078	0,171	0,196	0,250	0,225	0,184	0,137	0,038	0,01		0,05	
Brown	0,445	0,352	0,445	0,382	0,602	0,396	0,551	0,442	0,01		0,03	
White	0,350	0,360	0,300	0,310	0,290	0,320	0,340	0,370	0,40		0,75	
Grey	0,440	0,382	0,285	0,264	0,285	0,332	0,440	0,432	0,08	0,24	0,16	0,24
Black	0,385	0,355	0,300	0,270	0,260	0,310	0,345	0,395		0,03		0,03

When points lie on the spectral boundary, they shall be joined by that boundary and not by a straight line.

#### 7.3.1.4 Mean luminance

When measured in accordance with 7.3.1.7, transilluminated signs shall conform to Table 19.

Table 19 — Mean luminance  $L$  of transilluminated signs

unit:  $\text{cd}\cdot\text{m}^{-2}$

Colour	Class L1	Class L2	Class L3	Class LS
White	$40 \leq L < 150$	$150 \leq L < 300$	$300 \leq L \leq 900$	$10 \leq L < 40$
Yellow	$30 \leq L < 100$	$100 \leq L < 300$	$300 \leq L \leq 900$	$7.5 \leq L < 30$
Red	$6 \leq L < 20$	$20 \leq L < 50$	$50 \leq L \leq 110$	$1.5 \leq L < 6$
Blue	$4 \leq L < 10$	$10 \leq L < 40$	$40 \leq L \leq 80$	$1 \leq L < 4$
Green	$8 \leq L < 20$	$20 \leq L < 70$	$70 \leq L \leq 180$	$2 \leq L < 8$
Dark Green	$4 \leq L < 10$	$10 \leq L < 40$	$40 \leq L \leq 80$	$1 \leq L < 4$
Brown	$4 \leq L < 10$	$10 \leq L < 40$	$40 \leq L \leq 80$	$1 \leq L < 4$

Class LS may be used in those Member States using electro-luminescent material and is recommended for use only when the sign face material is translucent retroreflective.

#### 7.3.1.5 Luminance contrast of transilluminated signs $K$

When measured in accordance with 7.3.1.7, the luminance contrast of transilluminated signs, as determined by the ratio of the luminance of the contrast colour to the luminance of the colour, shall conform to the requirements of Table 20.

**Table 20 — Luminance contrast  $K$  of transilluminated signs**

Colour	Blue	Red	Green	Dark Green	Brown
Contrast colour	White	White	White	White and yellow	White
Luminance contrast	$5 \leq K \leq 15$	$5 \leq K \leq 15$	$5 \leq K \leq 15$	$5 \leq K \leq 15$	$5 \leq K \leq 15$

**7.3.1.6 Uniformity of luminance**

When measured in accordance with the procedures specified in 7.3.1.7, the uniformity of luminance, determined by the ratio of the lowest to the highest level measured at any part of the background colour of the sign, shall conform to the requirements of Table 21.

**Table 21 — Uniformity of luminance**

Class	Maximum ratio
U1	1/10
U2	1/6
U3	1/3

**7.3.1.7 Test methods for the mean luminance, the luminance contrast and the uniformity of luminance****7.3.1.7.1 Procedure**

The test procedure shall be as follows.

Mount the transilluminated sign with the sign face vertical.

Stabilize the supply voltage at the supply voltage declared by the manufacturer.

Divide the sign face into test squares commencing at the centre of the sign face. The side of the test squares shall be either 10 % of the sign height or 100 mm, whichever is greater.

Using a luminance meter conforming to EN 13032-1, measure the luminance of each test square in a direction normal to the test square so that the circular area of the measuring spot falls on the centre of the test square and is larger than 10 % of the test square area. Omit measurement for those test squares where the area of the circular measuring spot falls partly outside the sign face, or includes other colours than the background colour.

Calibrate the luminance meter across the full range of measurements. After the application of any photometric correction factors, calculate the mean luminance value and the luminance uniformity as the ratio of minimum to maximum luminance.

For any other colour of the sign face, measure the luminance of that colour at a suitable location in a direction perpendicular to the location using a measuring spot fully contained within an area with that colour. Measure also the luminance of the background colour at a location as close as possible to the above-mentioned location with the measuring spot fully contained within the background colour.

Calculate the luminance contrast as the ratio of the luminance of a white or yellow colour to the luminance of a blue, red, green, dark green or brown colour.

### 7.3.1.7.2 Test report

Report the test details, the luminance of each of the squares tested, the mean luminance, the luminance uniformity and for each colour of the sign in addition to the background colour, the luminance of that colour and of the background colour and the luminance contrast.

### 7.3.1.8 Durability of visual performance

Test samples of sign face material shall be exposed, inclined at an angle of 45° to the horizontal and facing the equator, in accordance with EN ISO 877:1996, Method A for two years.

When tested after exposure, the chromaticity and luminance factor shall conform to the requirements of 7.4.1.4.

The testing procedure for retroreflective materials using microprismatic technology can be found in the relevant European Technical Approval (ETA).

## 7.3.2 Physical performance

Sign housings for transilluminated signs shall be designed to ensure reliable transfer of all static and dynamic forces to the fixing and mounting structures. The walls of the housing shall be designed to satisfy the static requirements. The design shall ensure that rainwater does not run off the housing and down the sign face.

## 7.4 Externally illuminated signs

### 7.4.1 Non-retroreflective signs

#### 7.4.1.1 General

Non-retroreflective externally illuminated signs shall conform to 7.3.

#### 7.4.1.2 Mean illuminance

When verified in accordance with the procedures specified in 7.4.1.4 the mean illuminance of the sign face shall conform to Table 22.

**Table 22 — Mean illuminance *E* unit lux (lx)**

Class E1	Class E2	Class E3	Class E4	Class E5
$40 \leq E < 100$	$100 \leq E < 400$	$400 \leq E < 1500$	$1500 \leq E < 3000$	$3000 \leq E < 9000$

NOTE Classes E2, E3, E4 and E5 are comparable to classes L1, L2 L3 and L4 respectively for transilluminated signs.

#### 7.4.1.3 Uniformity of illuminance

When verified in accordance with the procedures specified in 7.4.1.4, the uniformity of illuminance, determined by the ratio of the lowest to the highest level measured at any part of the sign, shall conform to Table 23.

**Table 23 — Uniformity of illuminance *UE* of externally illuminated road signs**

Class UE1	Class UE2	Class UE3
$UE \geq 1/10$	$UE \geq 1/6$	$UE \geq 1/3$

NOTE Classes UE1, UE2 and UE3 are comparable to classes U1, U2 and U3 respectively for transilluminated signs.

#### **7.4.1.4 Test method and calculation method for the illuminance and the uniformity of illuminance**

##### **7.4.1.4.1 General**

Either method may be used but the manufacturer shall declare the method.

The test procedure shall be as in 7.4.1.4.2 to 7.4.1.4.3.

##### **7.4.1.4.2 Calculation method**

The luminaire intensity data to be used in calculation shall be obtained by measurement of the luminaire in accordance with EN 13032-1.

The presentation of intensity data and method of calculation shall conform to EN 13201-3, except that the position of calculation points shall be as the position of measurement points in 7.4.1.4.3, and the relevant area for calculation shall be the area of the sign face.

##### **7.4.1.4.3 Test method**

Mount a flat plate marked so as to define an area having the same dimensions as the sign plate with which the luminaire is intended for use, and mount the luminaire in relation and attitude to this area as intended to be used in the works.

Stabilize the supply voltage to the external lighting luminaire at the supply voltage declared by the manufacturer.

Divide the area representing the sign face into test squares, commencing at the centre of the sign face. The side of the test squares shall be either 10 % of the sign height or 100 mm, whichever is greater.

Using an illuminance meter conforming to EN 13032-1, measure the illuminance at the plane of the sign face in the centre of each test square. Omit measurement for those incomplete squares where the centre of the square falls outside the defined sign face area. After the application of any photometric correction factors, calculate the mean illuminance value and the illuminance uniformity as the ratio of minimum to maximum illuminance.

Calibrate the illuminance meter across the full range of measurements. Report the test details, the illuminance of each of the squares tested, the mean illuminance and the ratio of minimum to maximum illuminance.

#### **7.4.2 Retroreflective signs**

##### **7.4.2.1 General**

Retroreflective externally illuminated signs shall conform to Clause 4.

##### **7.4.2.2 Mean illuminance and uniformity of illuminance**

Retroreflective externally illuminated signs shall conform to 7.4.1.2 and 7.4.1.3.

##### **7.4.2.3 Impact resistance**

When tested in accordance with EN ISO 6272, using a mass of 450 g with a contact radius of 50 mm dropped from a height of 220 mm, there shall be no cracking or, for sign face sheeting material, delamination from any substrate, outside a circle of 6 mm radius with the point of impact as the centre.

The test sign shall be supported as it would be when installed, or the test sample shall be supported over an open area of 100 mm x 100 mm.

## **8 Sign assemblies**

Components for sign assemblies shall conform to the relevant sections of this document.

## **9 Marking, labelling and product information**

### **9.1 General**

The manufacturer shall provide the following information. Where this cannot be marked on the product it shall be in the accompanying documentation. In this event there shall be a product identification code on the product.

### **9.2 Marking and labelling**

All products and components mentioned in the scope shall be clearly and durably marked on the back with the following information:

- 1) number and date of this European Standard;
- 2) relevant performance classification of the product;
- 3) last two digits of the year of manufacture;
- 4) name, trade mark or other means of identification of the manufacturer or supplier when not the manufacturer;
- 5) batch or lot number.

Retroreflective sheetings used in the manufacture of fixed traffic signs shall have a durable and visible identification mark. The durability of the mark shall be equivalent to the expected lifetime of the retroreflective sheeting and the mark shall be visible on the finished product. The mark shall contain at least the following information:

- manufacturer's identification logo or symbol;
- production identification code; and
- retroreflective performance class as specified in EN 12899-1 or the relevant ETA.

All information shall be consistently repeated at least once within an area of 400 mm × 400 mm.

NOTE Additional information can be provided.

Where regulatory marking requires the same information as this subclause, then the requirements for information in accordance with this subclause are deemed to be satisfied.

### **9.3 Product information**

The manufacturer or supplier shall make available the following information:

- instructions on the assembly and erection of the sign;
- details of any limitations on location or use;

- instructions on the operation, maintenance and cleaning of the sign, including lamp replacement procedures.

#### **9.4 Luminaires**

The manufacturer shall provide a luminous intensity distribution to prove conformity to the other relevant requirements of this standard.

### **10 Evaluation of conformity**

The conformity of a vertical road traffic sign to the requirements of this standard and with the stated values (including classes) shall be demonstrated by:

- initial type testing in accordance with EN 12899-5; and
- factory production control by the manufacturer in accordance with EN 12899-4.

A FPC system conforming to the requirements of EN ISO 9001 and made product specific to the requirements of this standard shall be considered to satisfy FPC requirements in accordance with this standard.

### **11 Dangerous substances**

Materials used in products shall not release any dangerous substances in excess of the maximum permitted levels specified in a relevant European Standard for the material or permitted in the national regulations of the member state of destination.

**Annex A**  
(normative)

**Test points for horizontal and vertical loads**

**A.1 Wind load**

**A.1.1 Sign mounted symmetrically on a single support**

Horizontally-applied, uniformly-distributed load.

(Only wind load on sign plate is shown).

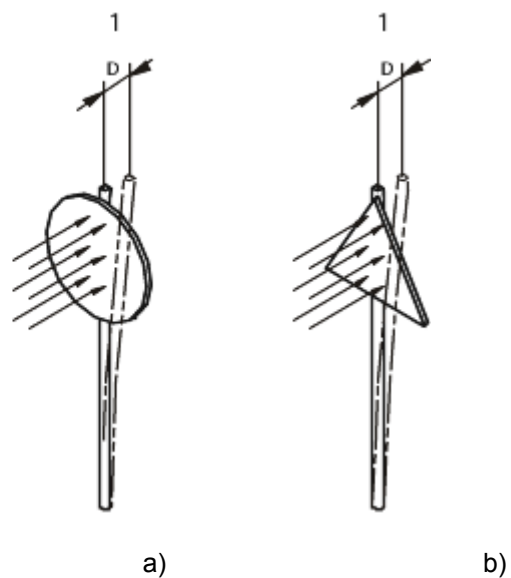

**Key**

1 deflection (D) of support

**Figure A.1 — Deflection of support**



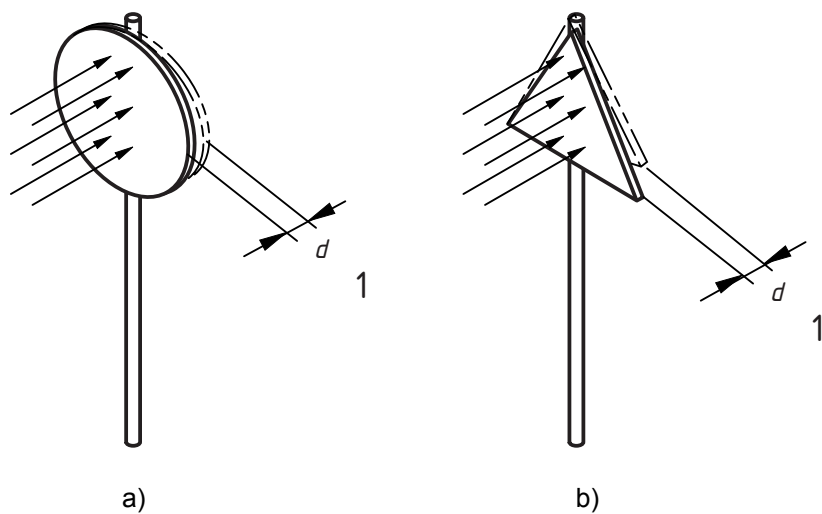

**Key**

1 deflection (d) of sign plate

**Figure A.2 — Deflection of sign plate**

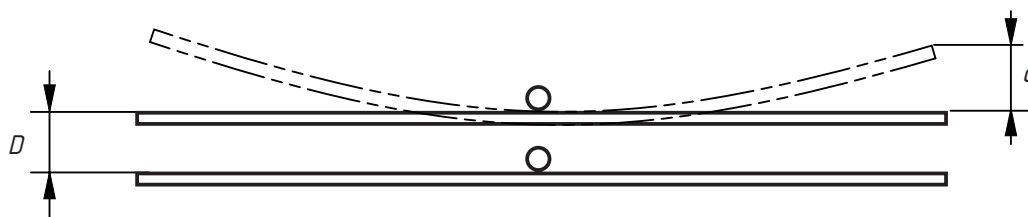

**Figure A.3 — Combined deflection of support and sign plate mounted symmetrically on a single support**

**A.1.2 Sign mounted asymmetrically on a single support**

Horizontally-applied, uniformly-distributed load.  
(Only wind load on sign plate is shown).

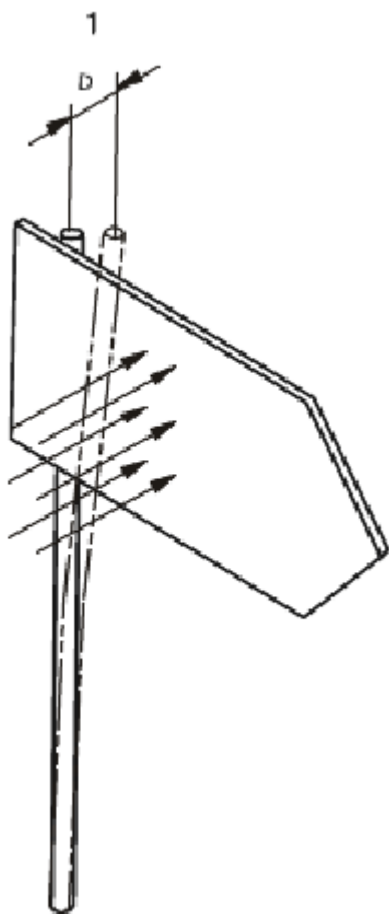

a)

**Key**

1 bending ( $D$ ) of support



b)

**Key**

1 rotation ( $\theta$ ) of support

**Figure A.4 — Deflection of support**

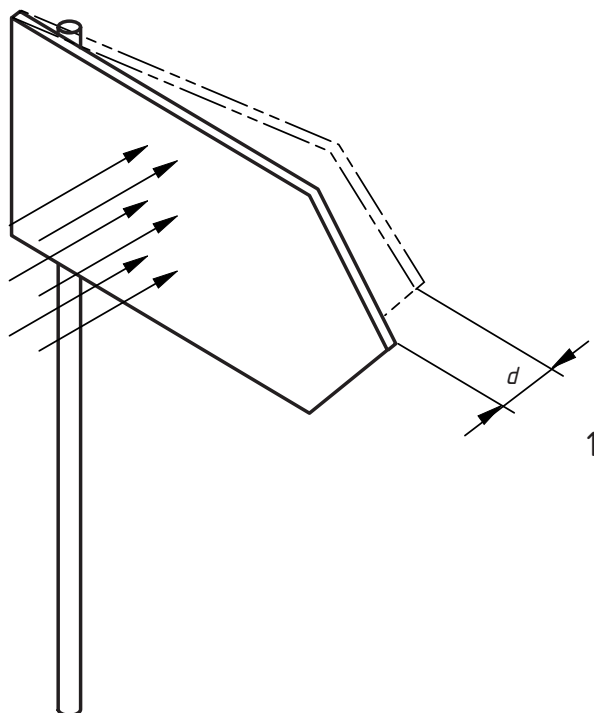

**Key**

1 deflection of sign plate

**Figure A.5a**

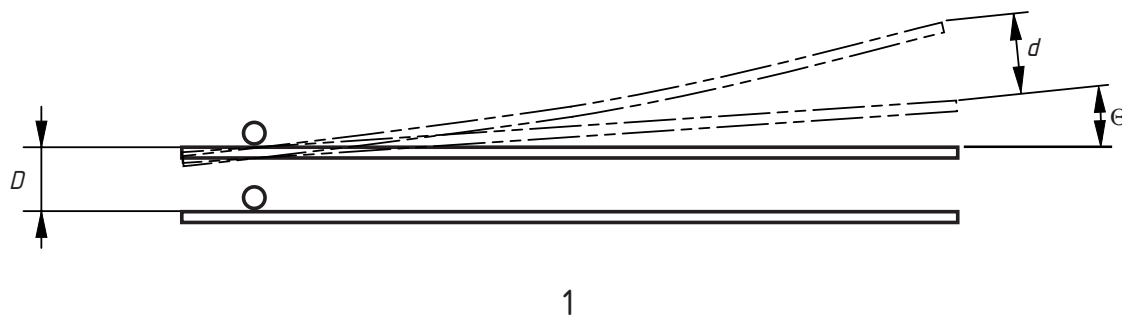

**Key**

$\Theta$  rotation of support

d deflection of sign plate

**Figure A.5b**

**Figure A.5 — Deflection of sign plate and supports**

### A.1.3 Sign mounted on two supports or more

Horizontally-applied, uniformly-distributed load.  
(Only wind load on sign plate is shown).

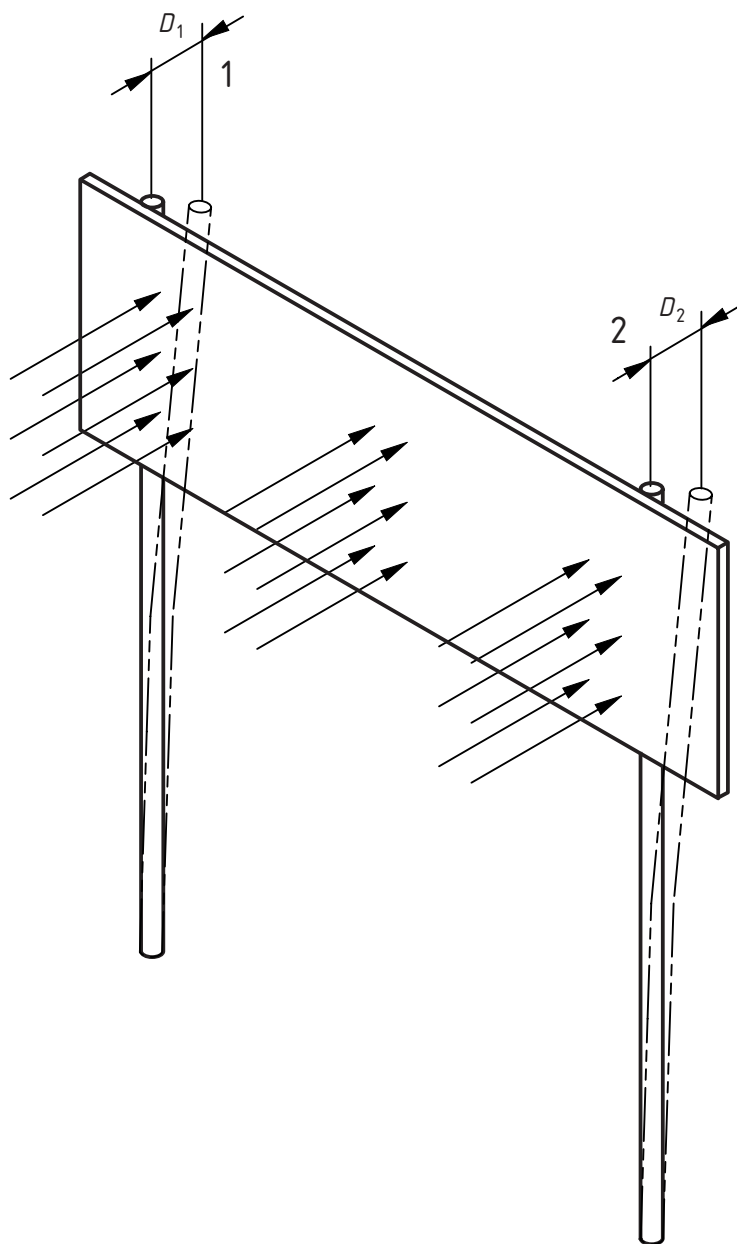

**Key**

- 1 deflection (D1) of support
- 2 deflection (D2) of support

**Figure A.6 — Deflection of supports**

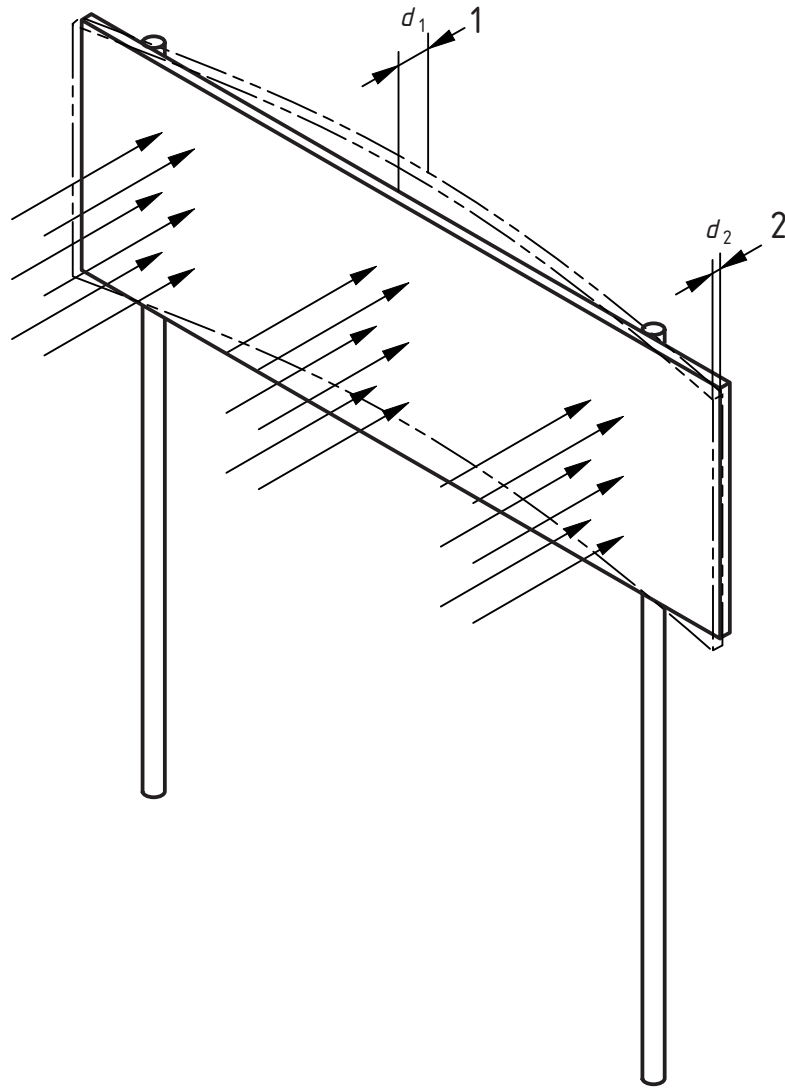
**Key**

- 1 deflection ( $d_1$ ) of sign plate
- 2 deflection ( $d_2$ ) of sign plate

**Figure A.7 — Deflection of sign plate**

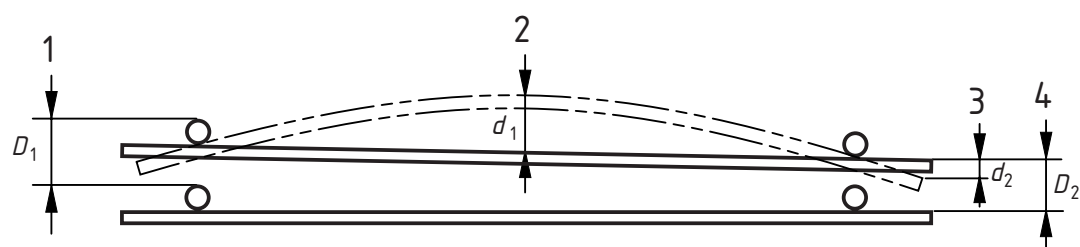

**Key**

- 1 deflection  $D_1$  of supports
- 2 deflection  $d_1$  of sign plate
- 3 deflection  $d_2$  of sign plate
- 4 deflection  $D_2$  of supports

**Figure A.8 — Combined deflection of supports and sign plate – Point load**

**A.1.4 Sign mounted symmetrically on a single support**

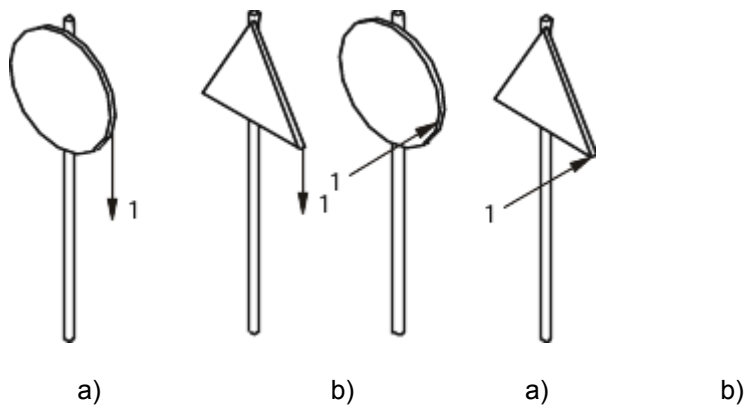

**Key**

- 1 Point load

**Key**

- 1 Point load

**Figure A.9 — Vertical load**

**Figure A.10 — Horizontal load**

**A.1.5 Sign mounted asymmetrically on a single support**

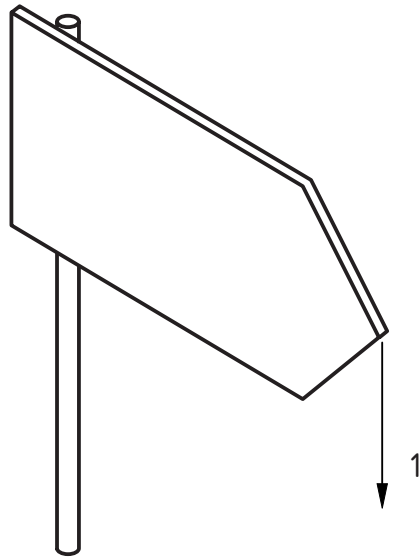

**Key**

1 Point load

**Figure A.11 — Vertical load**

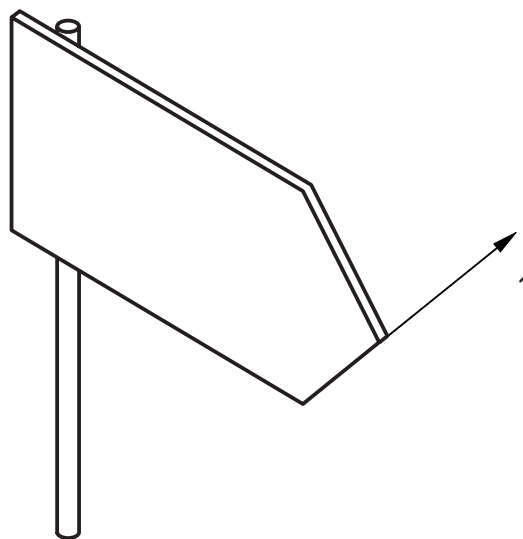

**Key**

1 Point load

**Figure A.12 — Horizontal load**

A.1.6 Sign mounted on two supports or more

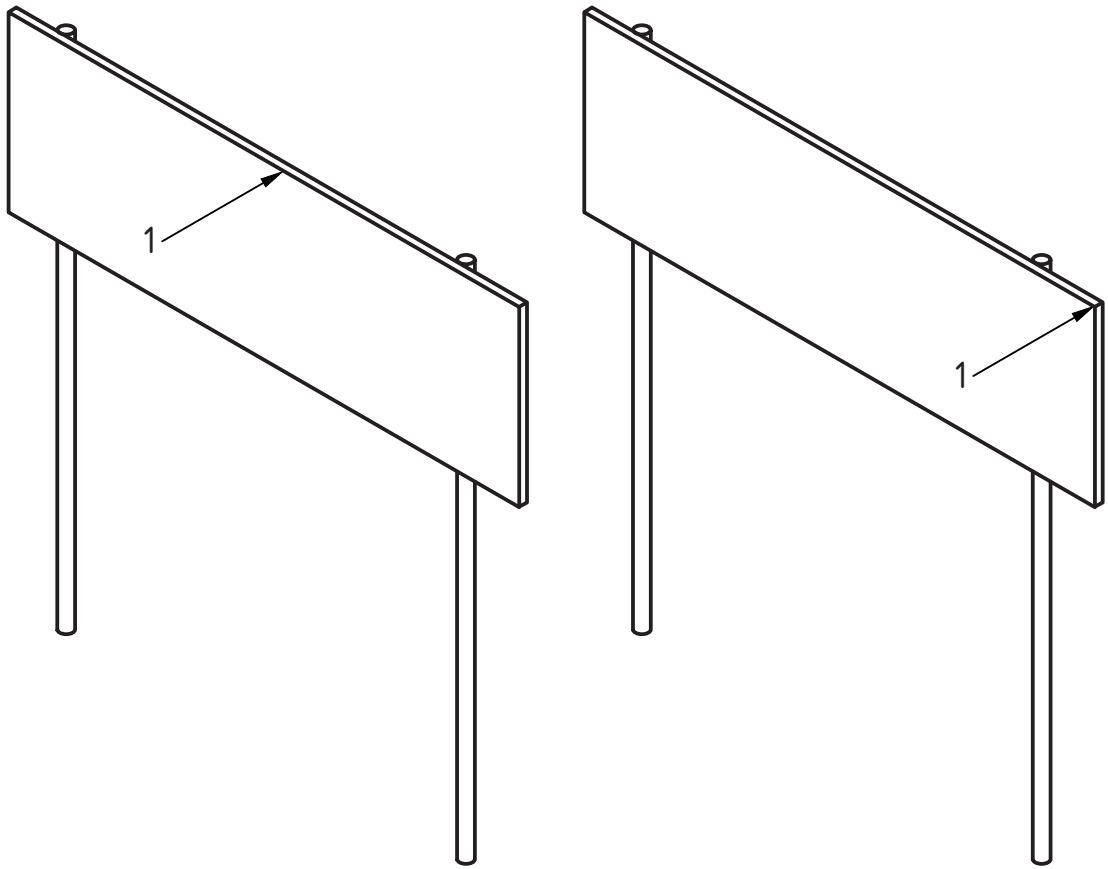

a)

b)

Key

1 Point load

Figure A.13 — Horizontal load



## A.2 Snow clearance, dynamic load, load combination

### A.2.1 Small signs mounted on a single support

Dimensions in millimetres

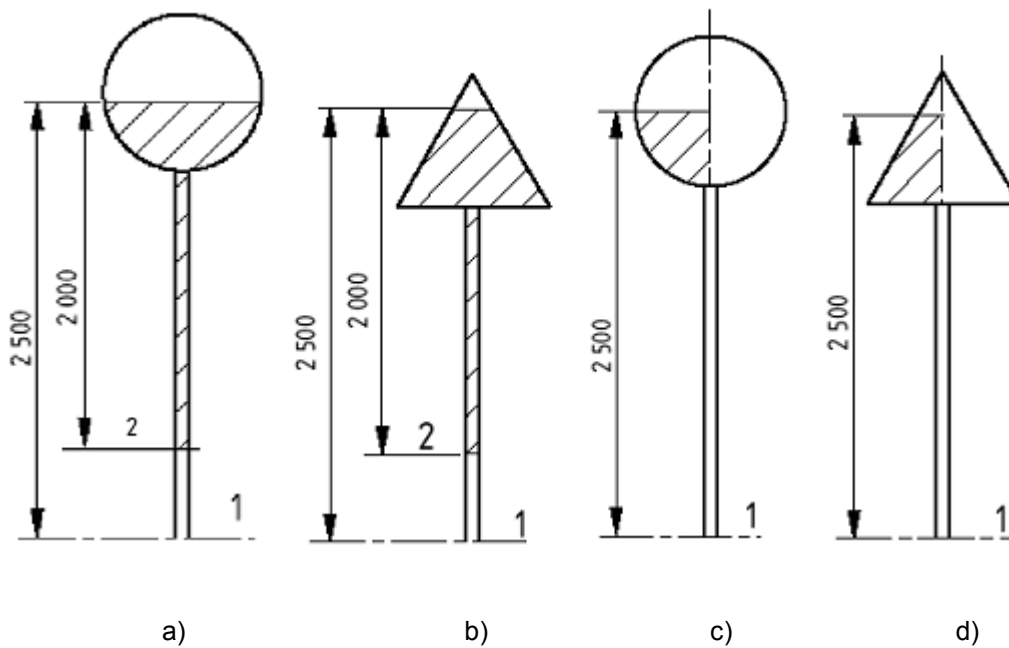

#### Key

- 1 ground level
- 2 road surface

a and b are for determining the maximum bending moment.  
c and d are for determining the torsion

Figure A.14 — Small signs mounted on a single support

A.2.2 Large sign mounted on a single support

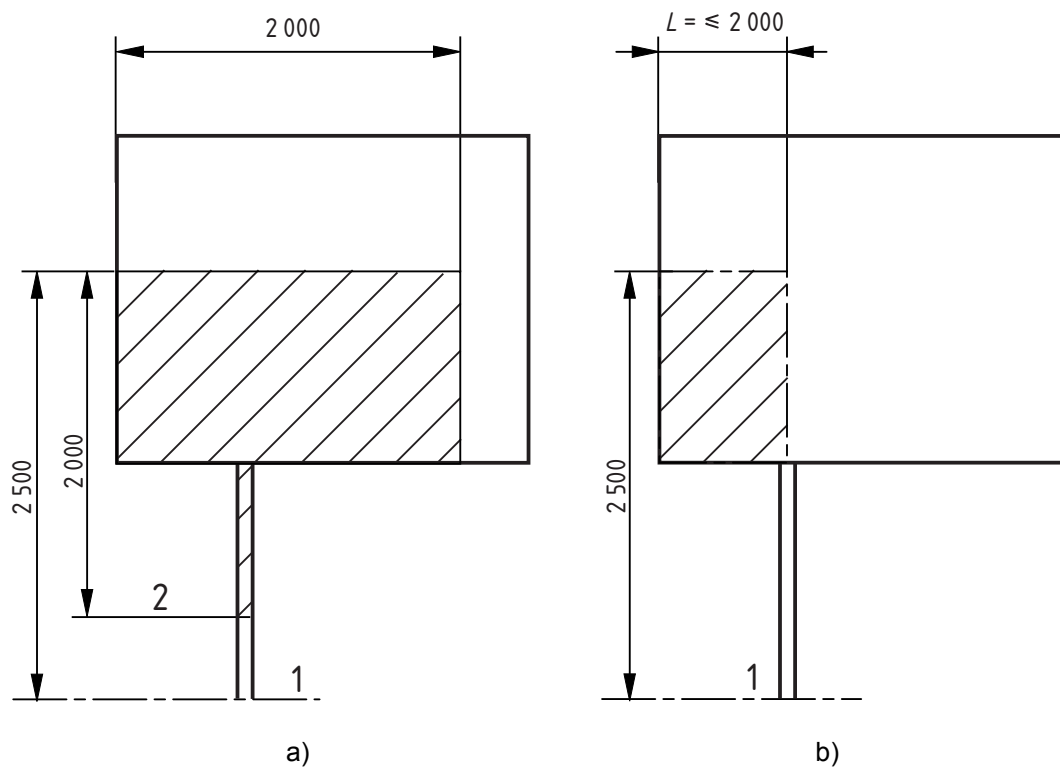

**Key**

1 ground level

2 road surface

a is for determining the maximum bending moment

b is for determining the torsion

**Figure A.15 — Large sign mounted on a single support**

Large signs mounted on two supports or more

Dimensions in millimetres

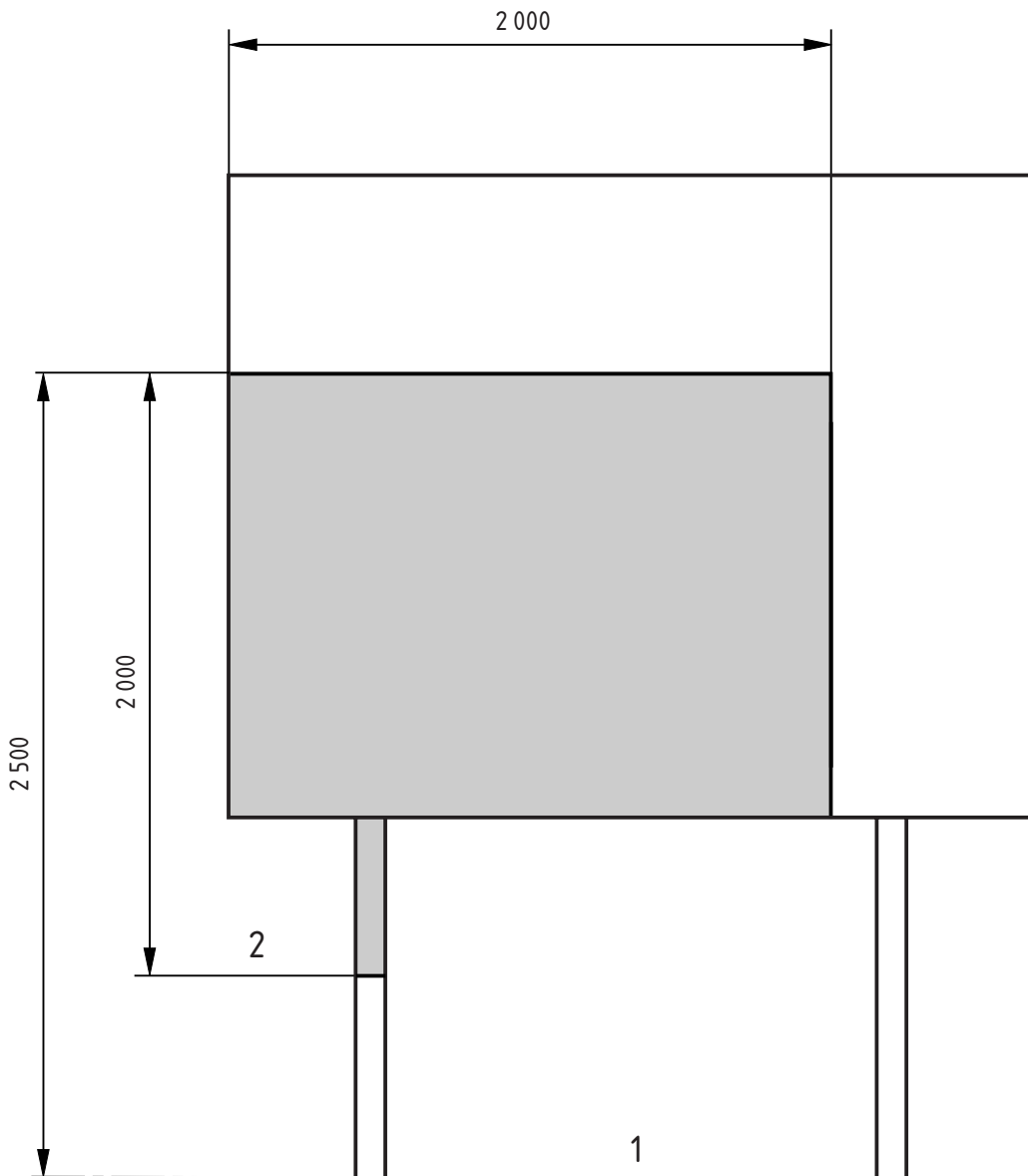

**Key**

- 1 ground level
- 2 road surface

 Area exposed to snow load from snow clearance

**Figure A.16 — Large signs mounted on two supports or more**

## Annex ZA (informative)

### Clauses of this European Standard addressing the provisions of the EU Construction Products Directive

#### ZA.1 Scope and relevant characteristics

This European Standard has been prepared under Mandate M/111 "Circulation Fixtures" given to CEN by the European Commission and the European Free Trade Association.

The clauses of this European Standard shown in this annex meet the requirements of the mandate given under the EU Construction Products Directive (89/106/EEC).

Compliance with these clauses confers a presumption of fitness of the fixed vertical road traffic signs covered by this annex for the intended uses indicated herein; reference shall be made to the information accompanying the CE marking.

**WARNING:** Other requirements and other EU Directives, not affecting the fitness for intended uses, can be applicable to the fixed vertical road traffic signs falling within the scope of this European Standard.

NOTE 1 In addition to any specific clauses relating to dangerous substances contained in this standard, there may be other requirements applicable to the products falling within its scope (e.g. transposed European legislation and national laws, regulations and administrative provisions). In order to meet the provisions of the EU Construction Products Directive, these requirements need also to be complied with, when and where they apply.

NOTE 2 An informative database of European and national provisions on dangerous substances is available at the Construction web site on EUROPA (accessed through <http://europa.eu.int/comm/enterprise/construction/internal/dangsub/dangmain.htm>).

This annex establishes the conditions for the CE marking of the fixed permanent signs intended for the uses indicated in Table ZA.1 and shows the relevant clauses applicable:

This annex has the same scope as Clause 1 of this standard and is defined by Tables ZA.2 to ZA.6.

**Table ZA.1 – Relevant clauses for retroreflective sheeting, using glass bead technology, for use on fixed vertical retroreflective road traffic signs**

<b>Construction product:</b> Retroreflective sheeting, using glass bead technology, for use with fixed vertical road traffic signs.			
<b>Intended use:</b> Material on permanent traffic signs.			
Requirement/ Characteristic from Mandate	Clauses in this European Standard meeting the Mandate	Mandated levels or classes	Notes
<b>Visibility characteristics</b>			
Daylight chromaticity & luminance factor	4.1.1.3	None	Pass/fail selected class
Retroreflectivity (Coefficient of retroreflection)	4.1.1.4	None	Pass/fail selected class $\text{cd.lx}^{-1}.\text{m}^{-2}$
<b>Durability</b>			
Impact resistance	4.1.2	None	Pass/fail
Resistance to weathering	4.1.1.5	None	Pass/fail When testing is done by accelerated artificial weathering, the validity shall be limited to four years.

Table ZA.2– Relevant clauses for supports supplied for fixed vertical signs

<b>Construction product:</b> Supports supplied for fixed vertical signs			
<b>Intended use:</b> Stock items (described by performance)			
Requirement/ Characteristic from Mandate	Clauses in this European Standard meeting the Mandate	Mandated levels or classes	Notes
Resistance to horizontal loads	5.1	None	Values of: maximum bending moment $M_u$ (kNm) and eccentricity value
Resistance to bending	5.1		Stiffness for bending $EI$ ( $\text{kNm}^2$ )
Resistance to torsion	5.1		Maximum moment for torsion $T_u$ (kNm) Stiffness for Torsion $GI_u$ ( $\text{kNm}^2$ ) For a non-constant cross section equivalent values shall be given related to the actual length of the support.
<b>Performance under vehicle impact (passive safety)</b>	6.3	None	Pass/fail selected class
<b>Durability</b>			
Corrosion resistance Metals Timber Plastics	7.1.7	None	Declared material, system of protection and class
Resistance to penetration of dust and water <sup>a</sup>	6.1 6.2	None	Pass/fail selected class
<sup>a</sup> If support provided with compartments for electrical equipment			

Table ZA.3– Relevant clauses for supports supplied for fixed vertical road traffic signs

<b>Construction product:</b> Supports supplied for fixed vertical road traffic signs.			
<b>Intended use:</b> Stock items (Described by material grade and geometric characteristics)			
Requirement/ Characteristic from Mandate	Clauses in this European Standard meeting the Mandate	Mandated levels or classes	Notes
<b>Resistance to horizontal loads</b>		None	Material and grade Geometric characteristics (dimensions) [The above must be sufficient for the purchaser to be able to establish the performance of the product]
<b>Performance under vehicle impact</b> (passive safety)	6.3	None	Pass/fail selected class
<b>Durability</b>			
<b>Corrosion resistance</b> Metals Timber Plastics	7.1.7	None	Declared material, system of protection and class

Table ZA.4 – Relevant clauses for supports supplied for fixed vertical road traffic signs

<b>Construction product:</b> Supports supplied for fixed vertical road traffic signs.			
<b>Intended use:</b> Stock items (Described by purchaser specification)			
Requirement/ Characteristic from Mandate	Clauses in this European Standard meeting the Mandate	Mandated levels or classes	Notes
<b>Resistance to horizontal loads</b>	Purchaser's design document reference number	None	The purchaser has taken responsibility for design to comply with the regulations for all characteristics in the country of intended use.
<b>Performance under vehicle impact</b> (passive safety)			
<b>Durability</b>			
<b>Corrosion resistance</b> Metals Timber Plastics			
Resistance to penetration of dust and water			

Table ZA.5 - Relevant clauses for sign plates for fixed vertical road traffic signs

Construction product: Sign plates with sign face materials applied for fixed vertical road traffic signs			
<b>Intended use:</b> Permanent traffic signs.			
Requirement/ Characteristic from Mandate	Clauses in this European Standard meeting the Mandate	Mandated levels or classes	Notes
<b>Resistance to horizontal loads</b>		None	
Fixings	7.1.14		Pass/fail
Wind actions	5.3.1		Selected value or class kN.m <sup>-2</sup>
Temporary deflection - bending	5.4.1		Pass/fail selected class mm/m
Dynamic load from snow clearance	5.3.2		Selected class kN.m <sup>-2</sup>
Point loads	5.3.3		Selected class kN
Permanent deflection	5.4.2		Pass/fail
Partial safety factor	5.2		Selected class
<b>Visibility characteristics</b>			
(Retroreflective signs)		None	
Daylight chromaticity & luminance factor	4.1.1.3; 4.2		Pass/fail selected class or ETA
Coefficient of retroreflection R <sub>A</sub>	4.2		Pass/fail selected class or ETA
(Non retroreflective signs)		None	
Daylight chromaticity & luminance factor	7.3.1.3		Pass/fail selected class
(Transilluminated retroreflective signs)		None	
daylight chromaticity & luminance factor	7.3.1.3		ETA
coefficient of retroreflection	4.2		ETA
mean luminance	7.3.1.4		Pass/fail selected class
luminance contrast	7.3.1.5		Pass/fail selected class
uniformity of luminance	7.3.1.6		Pass/fail selected class
(Transilluminated non retroreflective signs)		None	
daylight chromaticity & luminance factor	7.3.1.3		Pass/fail
mean luminance	7.3.1.4		Pass/fail selected class
luminance contrast	7.3.1.5		Pass/fail selected class
uniformity of luminance	7.3.1.6		Pass/fail selected class

<b>(External illumination)</b> mean illuminance uniformity of illuminance	7.4.1.2 7.4.1.3	None	Pass/fail selected class Pass/fail selected class
<b>Durability</b>			
<b>Impact resistance</b> Sign face material	4.1.2; 7.4.2.3, 7.2.2.2	None	Pass/fail
<b>Resistance to weathering – sign face material</b> Retroreflective signs  Non retroreflective signs	4.1.1.5, 4.2  7.2.2.1.4	None	Pass/fail three year accelerated natural weathering or ETA When testing is done on glass bead materials by accelerated artificial weathering, the validity shall be limited to four years  Two year accelerated natural weathering
<b>Corrosion resistance</b> Metals Timber Plastics	7.1.7	None	Declare material, system of protection and class
Resistance to penetration of dust and water <sup>a</sup>	6.1; 6.2	None	Pass/fail selected class
<sup>a</sup> If provided with compartments for electrical equipment			



Table ZA.6 - Relevant clauses for complete assemblies of fixed vertical road traffic signs

<b>Construction product:</b> Fixed vertical road traffic signs.			
<b>Intended use:</b> Complete assemblies of fixed vertical road traffic signs			
Requirement/ Characteristic from Mandate	Clauses in this European Standard meeting the Mandate	Mandated levels or classes	Notes
Resistance to horizontal loads	5.1	None	Values of: maximum bending moment $M_u$ (kNm) and eccentricity value
Resistance to bending	5.1		Stiffness for bending $EI$ (kNm <sup>2</sup> )
Resistance to torsion	5.1		Maximum moment for torsion $T_u$ (kNm) Stiffness for Torsion $GI_u$ (kNm <sup>2</sup> ) For a non-constant cross section equivalent values shall be given related to the actual length of the support.
<b>Resistance to horizontal loads</b>		None	
Fixings	7.1.14		Pass/fail
Wind actions	5.3.1		Selected value or class kN.m <sup>-2</sup>
Temporary deflection (sign plates)			
- bending	5.4.1		Pass/fail selected class mm/m
Temporary deflection (supports)			
- bending	5.4.1		Pass/fail selected class mm/m
- torsion	5.4.1		Pass/fail selected class degree/m
Dynamic load from snow clearance	5.3.2		Pass/fail selected class
Point loads	5.3.2		Snow pressure kN.m <sup>-2</sup> or class
Permanent deflection	5.4.2		and loaded area m <sup>2</sup>
Partial safety factor	5.2		Selected class kN Pass/fail Selected class
<b>Performance under vehicle impact (passive safety)</b>	6.3	None	Pass/fail selected class
<b>Visibility characteristics</b>			
(Retroreflective signs)		None	
Daylight chromaticity & luminance factor	4.1.1.3, 4.2		Pass/fail selected class or ETA
(Non retroreflective signs)		None	
Daylight chromaticity & luminance factor	7.3.1.3		Pass/fail selected class
(Retroreflective signs)		None	
Coefficient of retroreflection $R_A$	4.1.1.4, 4.2		Pass/fail selected class cd.lx <sup>-1</sup> .m <sup>-2</sup> or ETA

(Transilluminated retroreflective signs)		None	
daylight chromaticity & luminance factor	7.3.1.3		ETA
coefficient of retroreflection	4.2		ETA
mean luminance	7.3.1.4		Pass/fail selected class
luminance contrast	7.3.1.5		Pass/fail selected class
uniformity of luminance	7.3.1.6		Pass/fail selected class
(Transilluminated non retroreflective signs)		None	
daylight chromaticity & luminance factor	7.3.1.3		Pass/fail
mean luminance			
luminance contrast	7.3.1.4		Pass/fail selected class
uniformity of luminance	7.3.1.5 7.3.1.6		Pass/fail selected class Pass/fail selected class
<b>(External illumination)</b>		None	
mean illuminance & uniformity of illuminance	7.4.1.2 7.4.1.3		Pass/fail selected class Pass/fail selected class
<b>Durability</b>			
<b>Impact resistance</b>			
Sign face material	4.1.2, 7.4.2.3,	None	Pass/fail
<b>Resistance to weathering – sign face material</b>		None	
Retroreflective signs	4.1.1.5, 4.2		Pass/fail three year accelerated natural weathering or ETA. When testing is done on glass bead material by accelerated artificial weathering, the validity shall be limited to four years
Non retroreflective signs	7.2.2.1.4		Two year accelerated natural weathering
<b>Corrosion resistance</b>			
Metals	7.1.7	None	Declared material, system of protection and class
Timber			
Plastics			
Resistance to penetration of dust and water <sup>a</sup>	6.1; 6.2	None	Pass/fail selected class
<sup>a</sup> If provided with compartments for electrical equipment			

The requirement for a certain characteristic is not applicable in those Member States (MSs) where there are no regulatory requirements for that characteristic for the intended use of the product. In this case, manufacturers placing their products on the market of these MSs are not obliged to determine nor declare the performance of their products with regard to this characteristic and the option “No performance determined” (NPD) in the information accompanying the CE marking (see ZA.3) may be used. The NPD option may not be used, however, where the characteristic is subject to a threshold level.

## ZA.2 Procedure for attestation of conformity of fixed vertical road traffic signs

### ZA.2.1 System of attestation of conformity

The system of attestation of conformity of fixed vertical road traffic signs indicated in Table ZA.1, in accordance with the Decision of the Commission 96/579/EC] of 1996-06-24 as given in Annex III of the mandate for circulation fixtures, is shown in Table ZA.7 for the indicated intended use:

**Table ZA.7 – System of attestation of conformity**

Product	Intended use	Level(s) or class(es)	Attestation of conformity system(s)
Vertical road signs - permanent fixed signs	Permanent traffic signs installed permanently for the information, guidance, warning and direction of vehicle drivers and pedestrians.		1
System 1: See Directive 89/106/EEC (CPD) Annex III.2.(i), without audit testing of samples			

The attestation of conformity of the fixed vertical signs in Tables ZA.1 to Table ZA.6 shall be based on the evaluation of conformity procedure indicated in Table ZA.8 resulting from application of the clauses of EN 12899-5 and EN 12899-4 indicated therein.

**Table ZA.8— Assignment of evaluation of conformity tasks**

Tasks	Content of the task	Evaluation of conformity clauses to apply	
Responsibility of the manufacturer	Factory production control (FPC)	Parameters related to all relevant characteristics of Table ZA.1	EN 12899-4
	testing of samples taken at factory	All characteristics of Table ZA.1	EN 12899-4
Responsibility of the product certification body	Initial type testing	All characteristics of Table ZA.1	EN 12899-5
	Initial inspection of factory and of FPC	Parameters related to all relevant characteristics of Table ZA.1	EN 12899-4
	Continuous surveillance, assessment and approval of FPC	Parameters related to all relevant characteristics of Table ZA.1	EN 12899-4

### ZA.2.2 EC Certificate and Declaration of conformity

When compliance with the conditions of this annex is achieved, the certification body shall draw up a certificate of conformity (EC Certificate of conformity), which entitles the manufacturer to affix the CE marking. The certificate shall include:

- name, address and identification number of the certification body;
- name and address of the manufacturer, or his authorised representative established in the EEA, and place of production;
- description of the product (type, identification, use);
- provisions to which the product conforms (i.e. Annex ZA of this EN);

## EN 12899-1:2007 (E)

- particular conditions applicable to the use of the product (e.g. provisions for use under certain conditions);
- number of the certificate;
- conditions and period of validity of the certificate, where applicable;
- name of and position held by, the person empowered to sign the certificate.

In addition, the manufacturer shall draw up a declaration of conformity (EC Declaration of conformity) including the following:

- name and address of the manufacturer or his authorised representative established in the EEA;
- name and address of the certification body;
- description of the product (type, identification, use), and a copy of the information accompanying the CE marking;
- provisions to which the product conforms (i.e. Annex ZA of this EN);
- particular conditions applicable to the use of the product (e.g. provisions for use under certain conditions);
- number of the accompanying EC Certificate of conformity;
- name of, and position held by, the person empowered to sign the declaration on behalf of the manufacturer or of his authorised representative.
- declaration and certificate shall be presented in the official language or languages acceptable to the Member State in which the product is to be used.

### ZA.3 CE marking and labelling

The manufacturer or his authorised representative established within the EEA is responsible for the affixing of the CE marking. The CE marking symbol to affix shall be in accordance with Directive 93/68/EC and shall be shown on the fixed permanent signs (or when not possible it may be on the accompanying label, the packaging or on the accompanying commercial documents e.g. a delivery note). The following information shall accompany the CE marking symbol:

- identification number of the certification body;
- name or identifying mark and registered address of the producer;
- last two digits of the year in which the marking is affixed;
- number of the EC Certificate of conformity or factory production control certificate (if relevant);
- reference to this European Standard [EN 12899-1:2007];
- description of the product: generic name, material, dimensions and intended use;
- information on those relevant essential characteristics listed in Table ZA.1 which are to be declared;
- declared values and, where relevant, level or class (including "pass" for pass/fail requirements, where necessary) to declare for each essential characteristic as indicated in "Notes" in Tables ZA.1 to Table ZA.6
- "No performance determined" for characteristics where this is relevant.

The "No performance determined" (NPD) option may not be used where the characteristic is subject to a threshold level. Otherwise, the NPD option may be used when and where the characteristic, for a given intended use, is not subject to regulatory requirements in the Member State of destination. Information shall be presented as follows, where practicable.

**On the product**

- "CE" symbol;
- name or identifying mark of the manufacturer;
- number and year of this European Standard (i.e. EN 12899-1:2007).

**In the accompanying commercial documents**

- all information on the product or packaging;
- identification of the type of product in accordance with EN 12899-1:2007 (e.g. sign post);
- registered address of the producer;
- last two digits of the year in which the product was manufactured;
- reference of the notified body and the number of EC certificate of conformity;
- identification of the characteristics of the product.

Figures ZA.1 to ZA.6 give examples of the information to be given on the product, label, packaging and/or commercial documents.

 01234	<i>CE conformity marking, consisting of the “CE”-symbol given in Directive 93/68/EEC.</i>
AnyCo Ltd, PO Box 21, B-1050 <b>07</b> 01234-CPD-00234	<i>Identification number of the certification body (where relevant)</i>  <i>Name or identifying mark and registered address of the producer</i> <i>Last two digits of the year in which the marking was affixed</i> <i>Certificate number (where relevant)</i>
<b>EN 12899-1:2007</b>  Retroflective glass bead sheeting for use on permanent vertical road traffic signs.  <b>Daylight chromaticity and luminance factors – RC1</b> <b>Coefficient of retroreflection – RA1</b> <b>Durability</b> Impact resistance of sign face material - Pass Resistance to weathering (three year accelerated natural weathering test) - Pass	<i>No. of European Standard</i>  <i>Description of product and information on regulated characteristics</i>

**Figure ZA.1 – Example of CE marking information for retroreflective sheeting, using glass bead technology, for use on fixed vertical retroreflective signs.**

 01234	<i>CE conformity marking, consisting of the “CE”-symbol given in Directive 93/68/EEC.</i>
AnyCo Ltd, PO Box 21, B-1050 <b>07</b> 01234-CPD-00234	<i>Identification number of the certification body (where relevant)</i>  <i>Name or identifying mark and registered address of the producer</i> <i>Last two digits of the year in which the marking was affixed</i> <i>Certificate number (where relevant)</i>
<b>EN 12899-1:2007</b>  Supports supplied as stock items for use with fixed vertical road traffic signs  <b>Resistance to horizontal loads -</b>  Maximum bending moment $M_u$ 100 kNm Stiffness for bending $EI$ 100 kNm <sup>2</sup> Maximum moment for torsion $T_u$ 100 kNm Stiffness for Torsion $GI_t$ 100 kNm <sup>2</sup> <b>Performance under vehicle impact</b> (passive safety) –                            100,NE,3 Durability Resistance to corrosion – Steel; hot dip galvanized, SP1 Resistance to penetration of dust and water – IP56	<i>No. of European Standard</i>  <i>Description of product and information on regulated characteristics</i>

**Figure ZA.2 – Example of CE marking information described in performance terms for supports supplied as stock items for supporting fixed vertical road traffic signs**

 01234
AnyCo Ltd, PO Box 21, B-1050  <b>07</b> 01234-CPD-00234
<b>EN 12899-1:2007</b>  Supports supplied as stock items for use with fixed vertical road traffic signs Material - Welded steel tube Grade - S355J2 Geometric characteristics - Diameter 89 mm, wall thickness 2 mm, length 3,2 m. <b>Performance under vehicle impact</b> (passive safety) – 100,NE,3 <b>Durability</b> Resistance to corrosion – Steel; hot dip galvanized; SP1

*CE conformity marking, consisting of the “CE”-symbol given in Directive 93/68/EEC.*

*Identification number of the certification body (where relevant)*

*Name or identifying mark and registered address of the producer  
Last two digits of the year in which the marking was affixed  
Certificate number (where relevant)*

*No. of European Standard*

*Description of product and information on regulated characteristics*

**Figure ZA.3 – Example of CE marking information for supports supplied for fixed vertical road traffic signs providing material and geometric information for the purchaser to determine the suitability of performance to comply with appropriate regulations for horizontal load.**

 01234
AnyCo Ltd, PO Box 21, B-1050  <b>07</b> 01234-CPD-00234
<b>EN 12899-1:2007</b> <b>Supports supplied for use with fixed vertical road traffic signs.</b> Clients specification document number

*CE conformity marking, consisting of the “CE”-symbol given in Directive 93/68/EEC.*

*Identification number of the certification body (where relevant)*

*Name or identifying mark and registered address of the producer  
Last two digits of the year in which the marking was affixed  
Certificate number (where relevant)*

*No. of European Standard*

*Description of product and information on regulated characteristics*

**Figure ZA.4 – Example of CE marking information for supports supplied for fixed vertical road traffic signs when the purchaser has supplied design specifications and taken the responsibility for compliance with appropriate regulations.**

 01234	<p><i>CE conformity marking, consisting of the “CE”-symbol given in Directive 93/68/EEC.</i></p> <p><i>Identification number of the certification body (where relevant)</i></p>
AnyCo Ltd, PO Box 21, B-1050  <b>07</b>  01234-CPD-00234	<p><i>Name or identifying mark and registered address of the producer</i></p> <p><i>Last two digits of the year in which the marking was affixed</i></p> <p><i>Certificate number (where relevant)</i></p>
<p><b>EN 12899-1:2007</b>                  Retroreflective sign plates with external illumination for fixed vertical road traffic signs  <b>Resistance to horizontal loads</b> -                  Fixings – Pass                  Wind action - WL2                  Temporary deflection bending – TDB5                  Dynamic snow load - DSL1                  Point loads - PL2                  Permanent deflection – Pass                  Partial action factor – PAF1  <b>Visibility characteristics</b>                  Daylight chromaticity &amp; luminance factor–CR1                  Coefficient of retroreflection – RA1                  Mean illuminance – E3                  Uniformity of illuminance – UE2  <b>Durability</b>                  Impact resistance of sign face material - pass  <b>Resistance to weathering (three year accelerated natural weathering test) - Pass</b>                  Resistance to corrosion – Aluminium; SP1                  Resistance to penetration of dust and water – IP56</p>	

**Figure ZA.5– Example of CE marking information for sign plates for fixed vertical road traffic signs.**



 01234	<i>CE conformity marking, consisting of the "CE"-symbol given in Directive 93/68/EEC.</i>
AnyCo Ltd, PO Box 21, B-1050  <b>07</b>  01234-CPD-00234	<i>Identification number of the certification body (where relevant)</i>  <i>Name or identifying mark and registered address of the producer</i> <i>Last two digits of the year in which the marking was affixed</i> <i>Certificate number (where relevant)</i>
<b>EN 12899-1:2007</b> Complete retroreflective fixed vertical road traffic sign assembly with external illumination <b>Resistance to horizontal loads</b> - Fixings – Pass Wind action - WL2 Temporary deflection bending (sign plate) – TDB5 Temporary deflection bending (supports) – TDB6 Temporary deflection torsion (supports) – TDT4 Dynamic snow load - DSL1, applied over 2 m <sup>2</sup> Point loads - PL2 Permanent deflection – Pass Partial action factor – PAF1 <b>Performance under vehicle impact</b> (passive safety) – 100,NE.3. Visibility characteristics Daylight chromaticity & luminance factor–CR1 Coefficient of retroreflection – RA1 <b>11.1.1 Mean illuminance – E3</b> <b>11.1.2 Uniformity of illuminance – UE2</b> <b>Durability</b> Impact resistance of sign face material - pass Resistance to weathering (three year accelerated natural weathering test) - Pass Resistance to corrosion of sign plate – Aluminium; SP1 Resistance to corrosion of supports – Steel; hot dip galvanized; SP1 Resistance to penetration of dust and water – IP56	

**Figure ZA.6 – Example of CE marking information for complete assemblies of fixed vertical road traffic signs.**

In addition to any specific information relating to dangerous substances shown above, the product should also be accompanied, when and where required and in the appropriate form, by documentation listing any other legislation on dangerous substances for which compliance is claimed, together with any information required by that legislation.

*NOTE European legislation without national derogations need not be mentioned.*